

# KITTERY WATER DISTRICT

## WATER LINE CONSTRUCTION SPECIFICATIONS

APRIL 2026

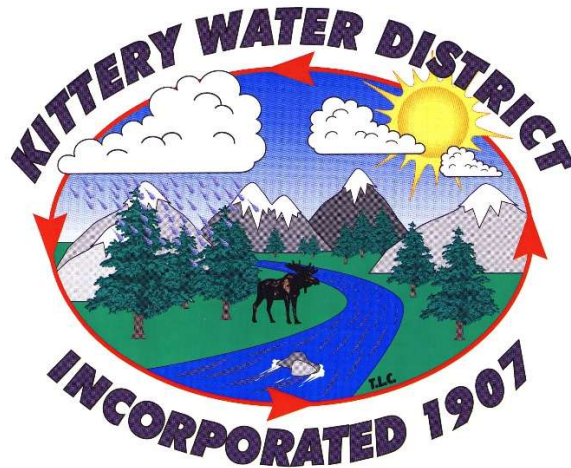

If you have any questions, please call the office at (207) 439-1128 or email at [info@kitterywater.org](mailto:info@kitterywater.org). Your inquiry will be directed to the appropriate staff member, who will follow up as quickly as is possible.

# Table of Contents

Introduction .....	3
Before Beginning Any Work .....	4
Installation Requirements.....	5
Water Line Construction Material Specifications.....	8
Standard 2 - Inch Blow Off Detail .....	11
New Meter Installation – Residential.....	12
New Meter Installation – Commercial.....	13
New Meter Installation – Eliot Deduct .....	14
New Meter Installation- Kittery Second Irrigation.....	15

## **Introduction**

This information is intended to inform and guide homeowners and contractors regarding procedures to follow while working on Kittery Water District (here after KWD) water lines. **This summary does not relieve the owner/contractor of the responsibility for meeting all State and Federal requirements pertaining to the installation of water and sewer lines.**

NOTE: Provided that both the material specifications and installation requirements of the KWD are followed, upon successful installation and testing of the underground and aboveground infrastructure, KWD will accept the ownership of the infrastructure for perpetuity. If the infrastructure is NOT located within the Town or State right-of-way, a Utility Easement will need to be issued to the KWD.

***NOTE: ALL PARTIES ARE STRONGLY ENCOURAGED TO READ THIS BOOKLET AND CALL WITH ANY QUESTIONS PRIOR TO STARTING WORK.***

*This information is subject to revision.*

## **Before Beginning Any Work**

1. The KWD requires **at least one week's notice** before any work can begin. This allows the KWD time to review the project with the owner/contractor and schedule installations and inspections, etc. **The owner/contractor must contact the KWD at (207) 439-1128 prior to beginning work.**
2. Pursuant to Federal Law, the owner/contractor must contact Dig Safe at 811, or 1-888-344-7233 at least three (3) working days prior to the date work is scheduled to begin. A Dig Safe Project Number is required prior to excavation.
3. The owner/contractor shall not operate any hydrants, valves or curb stops that are the property of the KWD, without the expressed permission of the KWD.
4. The owner/contractor shall be responsible for notifying all users/property owners affected, prior to shutting off any services. Appropriate agencies shall also be notified.

## **Installation Requirements**

### **INSPECTION SERVICES:**

Installation inspections will be performed by the District or its representative and paid for by the Developer or Contractor. Full time inspections will be performed by the District or its representative at the jobbing hourly rate. Inspections will be performed during regular business hours 7:00 am – 3:00 pm, Monday – Friday, unless a prior request is issued and approved by the KWD.

### **BEDDING AND BACKFILL:**

- Ledge must be fully excavated a minimum of 12” below and 12” on either side of the pipe.
- A Minimum of 6” of clean sand bedding under the pipe and 12” on either side of the pipe is required.
- Pipe Bedding – AWWA C600 Pipe Laying Sec. 4 standards shall be followed for the installations of water mains and appurtenances. Trenches shall be flat bottomed, with 6” of compacted clean sand beneath and 12” above the pipe. Where ledge is encountered, 12” of compacted clean sand shall be installed beneath the pipe. The trench will be kept dewatered during pipe laying.  
The pipe bedding shall be clean granular sand, free from organic matter, frozen material or any other objectionable material and shall meet the following requirement: 100% passing a 2” sieve.
- Stone Dust is NOT an acceptable substitute for sand.
- A Minimum of 12” of compacted sand above the pipe is required. Compaction can be accomplished by either the excavator bucket or a mechanical compactor.
- The remainder of the trench is to have compacted backfill material pre-approved by the District or its representative. Compaction of this material must be by a mechanical compactor.
- Minimum earth cover over the top of the pipe is 5’-0” (top of pipe to finish grade).
- Locking Tyton / Fastite gaskets shall be installed in the last 3 sections of pipe that is assembled before installing the blow-off assembly.
- The Blow-Off assembly will require that an MJ Tap Cap be installed which will require a spigot end of the pipe. (additional details below).
- Field cutting of pipe is not allowed within 3 feet of the bell of the pipe, unless the nominal O.D. of the pipe is maintained.

### **BLOW-OFF INSTALLATION (SEE DETAIL SHEETS):**

- High density polyethylene (H.D.P.E.) blow-offs are fabricated by KWD (time and material rates apply), and installed by the contractor.
- Valve shall be 2” ball valve, Riser shall be 2” H.D.P.E. plastic pipe.
- Contractor is responsible for backfilling once the Blow-Off and thrust blocks are installed.
- Sand backfill is required from the base of the valve and riser pipe to the top of the ground.
- Care must be taken not to dig beyond the blow-off installation area, such that thrust blocks can be set against undisturbed soil.
- 26” top flange valve box top sections and covers are to be installed over all Blow-Off assemblies, over the service box and over the riser pipe.

### **SERVICES LINE INSTALLATIONS:**

- Upon completion of the water main, and a passing pressure test, installation of services may be proceed.
- On Ductile mains, 1” direct taps will be performed, to a 1” cc Corp, to 1” “K” Copper Service Line, to a 1” Ballvalve Curb stop. The Curb stop will have a 36” s.s. Service Rod and a 4.5’-5.5’ Service Box. A Bibby with Cover labeled “Water” will be installed over the Service Box.
- On HDPE mains, 1” Service Saddles will be installed prior to tapping the main. A 1” cc Corp, to 1” CTS plastic Service Line, to a 1” Ballvalve Curb stop. The Curb stop will have a 36” s.s. Service Rod and a 4.5’-5.5’ Service Box. Tracer wire will be installed to the CTS line. A 6” top flange valve box top section with Cover labeled “WATER” will be installed over the Service Box.
- Clean sand bedding is also required 6” below the copper tubing and 12” to the sides and above. Sand backfill is also required around the service box, from the foot piece to the cap.
- Services that reach or exceed 150 feet from the curb stop will require a meter vault to be installed.

### **TEST SERVICE / CHLORINATION TAP:**

The KWD or Contractor shall install a 1” corporation and a CTS plastic riser with a 1” curb stop cnpj x feip, on the first length of water main that is installed, as close to the mainline valve as is practical. Upon successful completion of a pressure test, chlorination and a negative bacteria test, the Contractor shall excavate to allow removal of the test service and installation of a brass plug by either KWD or the Contractor (time and material rates apply).

### **FIRE HYDRANT INSTALLATIONS:**

- The traffic break flange of the hydrant shall not be less than 2” above the finish grade, nor more than 6” above the finish grade.
- Sand backfill is required around the barrel of the hydrant, from the shoe to the ground’s surface.
- Valve anchoring tees are to be used for all hydrant installations and lateral water mains.
- Marker poles will be provided by the District and installed by the contractor in the appropriate location (material rates apply).

### **WATER MAIN ACCEPTANCE POLICY:**

- The newly installed water main will be filled, flushed, hydrostatically tested and chlorinated by the contractor.
- A negative bacteria result is needed before the water is used for any reason. The contractor or KWD will take this sample and have it analyzed.
- An as-built drawing of the water main installation performed by a licensed surveyor or engineer is required before acceptance of the main by KWD.
- Receipt of an electronic version of the project plan.
- Acknowledgement and execution of any agreements (fire protection lines, fire hydrants, etc.).
- Execution of an Easement to the KWD, for any mains installed in non-public right of ways. This includes both the drafting and recording of the Easement.
- Payment shall be made to KWD for all invoiced services and materials.

## **METERS:**

- Meters are both supplied and installed by KWD (time and material rates apply).
- A sketch is available from the District, outlining the required plumbing setup to receive the meter.
- Type “L” Copper should be used in the installation.

## **NOTES:**

- All materials that are installed are to be made in the USA or Canada, unless otherwise approved by the KWD.
- Material Submittal Sheets (Cut Sheets) shall be submitted to the KWD for approvable prior purchasing the materials.
- Inspection and service work performed by KWD will be billed at the District’s current time and material rates. Services provided by a third party will be billed at their rate.
- The horizontal distance between water and sewer lines shall be a minimum of 10 feet. Anytime a sewer line crosses above a water main, one full section of typical sewer pipe must be replaced with a full section of SDR-21 quality pipe. The full section of SDR-21 pipe shall be centered upon the crossing to maximize joint distance from the watermain and shall have a minimum clearance of 18” above the watermain.
- During new construction groundwork, the Owner / Contractor is responsible for protecting any service or meter that may be in danger of freezing. Associated damage repair costs will be the responsibility of the Owner / Contractor.
- The installation of H.D.P.E. main and CTS Plastic service lines will require the installation of Copper Head Brand tracing wire and Snake Bite Brand connectors. The KWD has very specific requirements for the installation of the tracer wire. The on-site inspector will provide detailed guidance at the time of installation.
- GPK Products, Inc. Schedule 40 x SDR-35 G “No Stop” adaptors must be used for all SDR-35 to SDR-21 connections. Connections of SDR-21 to other types of sewer pipe shall use solid couplings. Flexible couplings will NOT be permitted.

# **Water Line Construction Material Specifications**

## **WATER MAIN:**

- Ductile Iron
- Class 52 thickness
- Tyton / Fastite joint
- Double cement lined
- Zinc coated

## **ALTERNATE WATER MAIN MATERIAL:**

- High Density Polyethylene (H.D.P.E.)
- SDR 11
- Butt Fusion / Electrofusion Couplings
- Blue Stripe
- Copper Head Brand tracer wire is required on the main and all laterals

## **DUCTILE IRON FITTINGS:**

- Class 350
- Made in the USA or Canada

## **DUCTILE IRON GATE VALVES:**

- 250 P.S.I. working pressure
- Open left
- Resilient wedge
- Valves 16" or greater must be Horizontal with Bevel Gear
- Stainless steel nuts and bolts
- Stainless steel or bronze operating nut
- Valve centering rings are required
- Mud plugs are required

## **FIRE HYDRANTS:**

- AFC Waterous Pacer WB 67
- Clow Medallion
- Kennedy Valve Guardian K81-D
- Open left
- Non draining barrel

## **SERVICE BOXES:**

- 4 ½' - 5 ½' height, cap with rope thread and pentagon nut

**VALVE BOXES:**

- Cast iron
- 36” top flange
- 36” bottom base belled (minimum length)
- 5 ¼” diameter
- Drop in cover with pick hole with the word “WATER” cast in the cover
- Made in the USA or Canada

**CORPORATIONS:**

- Minimum size 1” for residential
- Mac Pac compression style nut
- Ball construction
- AY McDonald or Ford brand
- CC thread type

**CURB STOPS:**

- Minimum size 1” for residential
- Mac Pac compression style nut
- Ball construction
- AY McDonald or Ford brand

**SERVICE LINES:**

- Service lines shall be K-copper tubing
- Minimum size of tubing is 1”
- CTS Plastic tubing may be used only when installing an H.D.P.E. main
- ALL service boxes are to be protected using a 5 ¼” x 6” valve box top extension with the cover stamped “WATER”

**STAINLESS STEEL SERVICE RODS:**

- 5/8” x 36” long, with Brass Cotter Pins

**TAPPING SLEEVE:**

- Series 304 stainless steel
- Ductile iron or stainless steel welded flange
- Size on size taps are NOT permitted on cast iron water mains

**RETAINER GLANDS:**

- Romac grip ring brand (R-Blue T-Bolts and nuts required)
- MJ Field Lok brand (R-Blue T-Bolts and nuts required)
- MEGA Lug brand (R-Blue T-Bolts and nuts required)

**SERVICE SADDLES:**

- Ductile Iron body
- Nylon coated body
- Double stainless steel straps
- Electrofusion service saddles with cc threads are required when using H.D.P.E. pipe



**2" Female Poly Cam Fitting with Plug, Valve Box Top Section and Cover.**

**KWD to provide 2" SDR Riser Pipe, and the Contractor will provide all other fittings per KWD detail**

**2" SDR 11 HDPE Riser (provided by the KWD)**

**2" Male Poly Cam Fitting, 2" Elbow, 2" x 12" Nipple, 2" FE x FE ball valve curb stop, 2" x 6" Nipple, 36" stainless steel rod, service box, Valve Box Top Section and Cover.**

**KITTERY WATER DISTRICT**  
**Standard 2 - Inch Blow Off Detail**

**This is a parts list beginning at the tapped MJ Cap or Plug:**

- 2" x 6" Brass Nipple
- 2" FE x FE Ball Valve Curb Stop
- 2" x 12" Brass Nipple
- 2" Brass Elbow
- 2" Male Poly Cam \*
- 2" SDR11 H.D.P.E. Pipe \*
- 2" Female Poly Cam \*
- 2" Brass Plug

**Also: After the assembly is installed:**

- Service Box Foot Piece
- Service Box (4' - 6" x 5' - 6")
- 36" x 5/8" Diameter Stainless Steel Service Rod
- Valve Box Cover (2)
- 26" Valve Box Top Section (2)

\* Riser Pipe is welded to the specified length by the Kittery Water District

## New Meter Installation – Residential

### New Meter Installation - Residential

\*KWD will provide meter spud, meter, and dual check valve.  
Meter sizes: 5/8", 3/4", 1" (Determined by water usage)

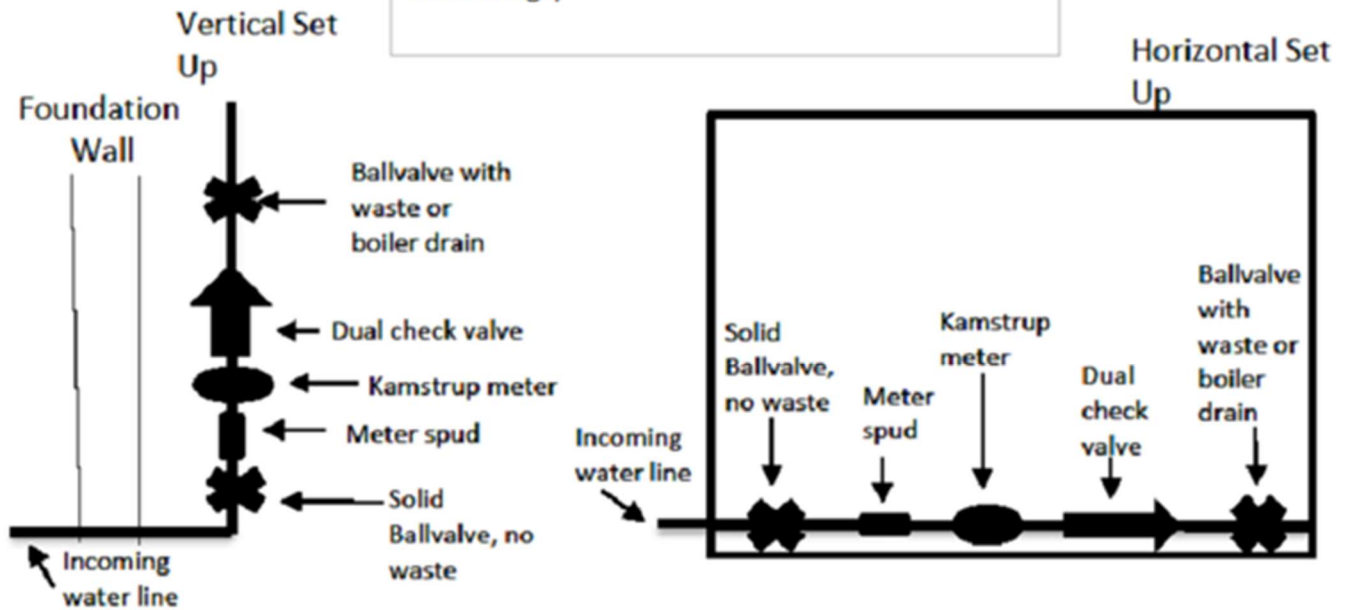

## New Meter Installation – Commercial

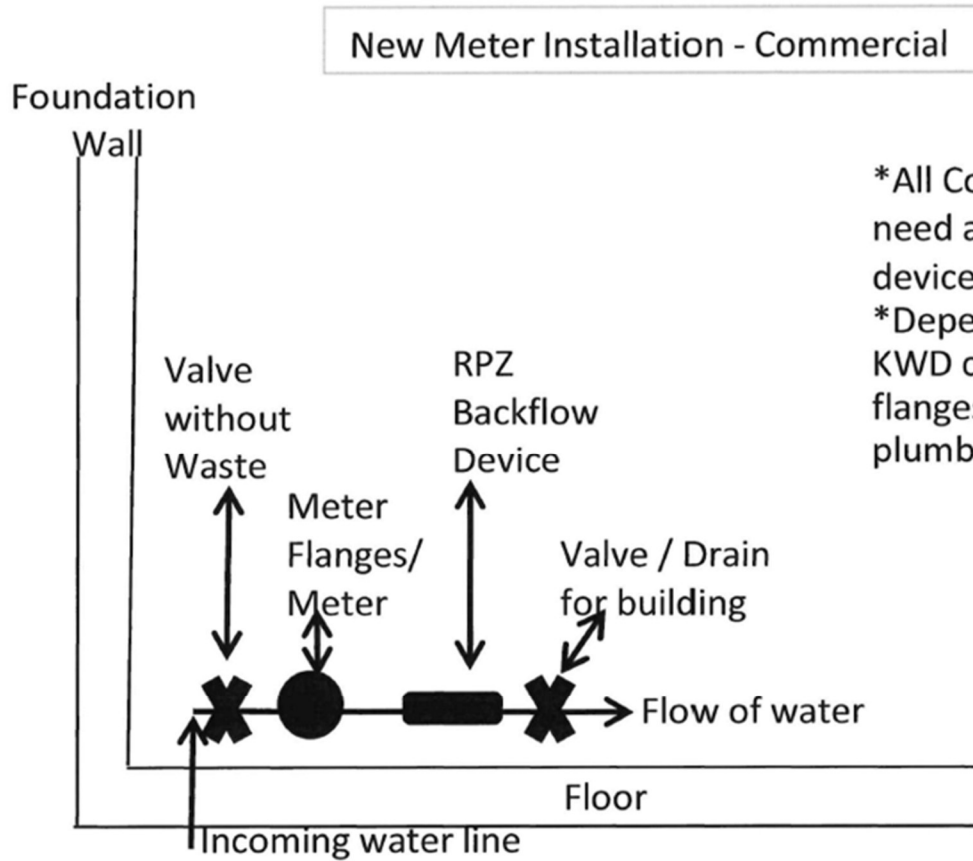

\*All Commercial properties need a testable RPZ backflow device.

\*Depending on size of meter, KWD can provide different flanges or tail pieces for the plumber.

## New Meter Installation – Eliot Deduct

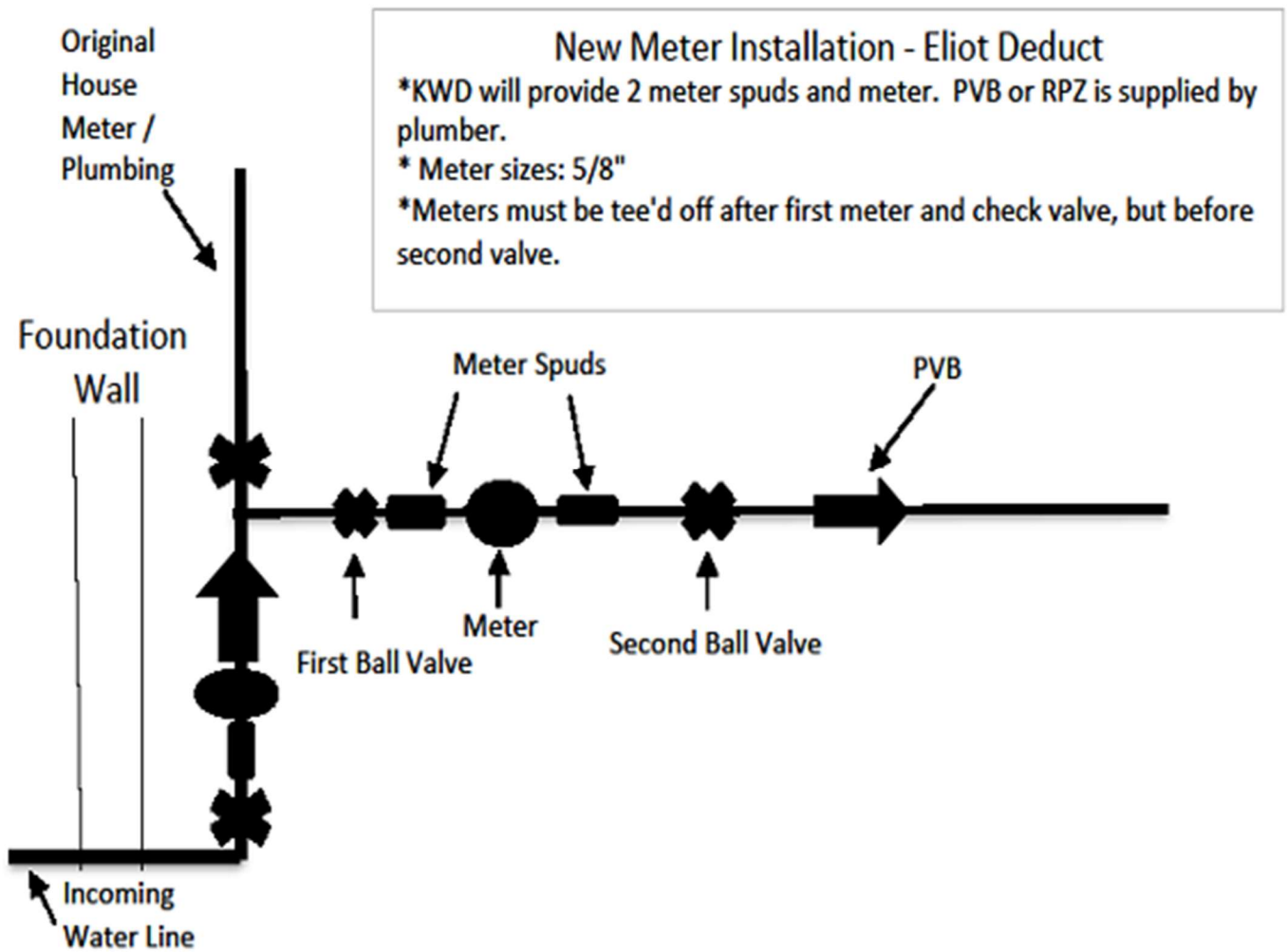

# New Meter Installation - Kittery Second Irrigation

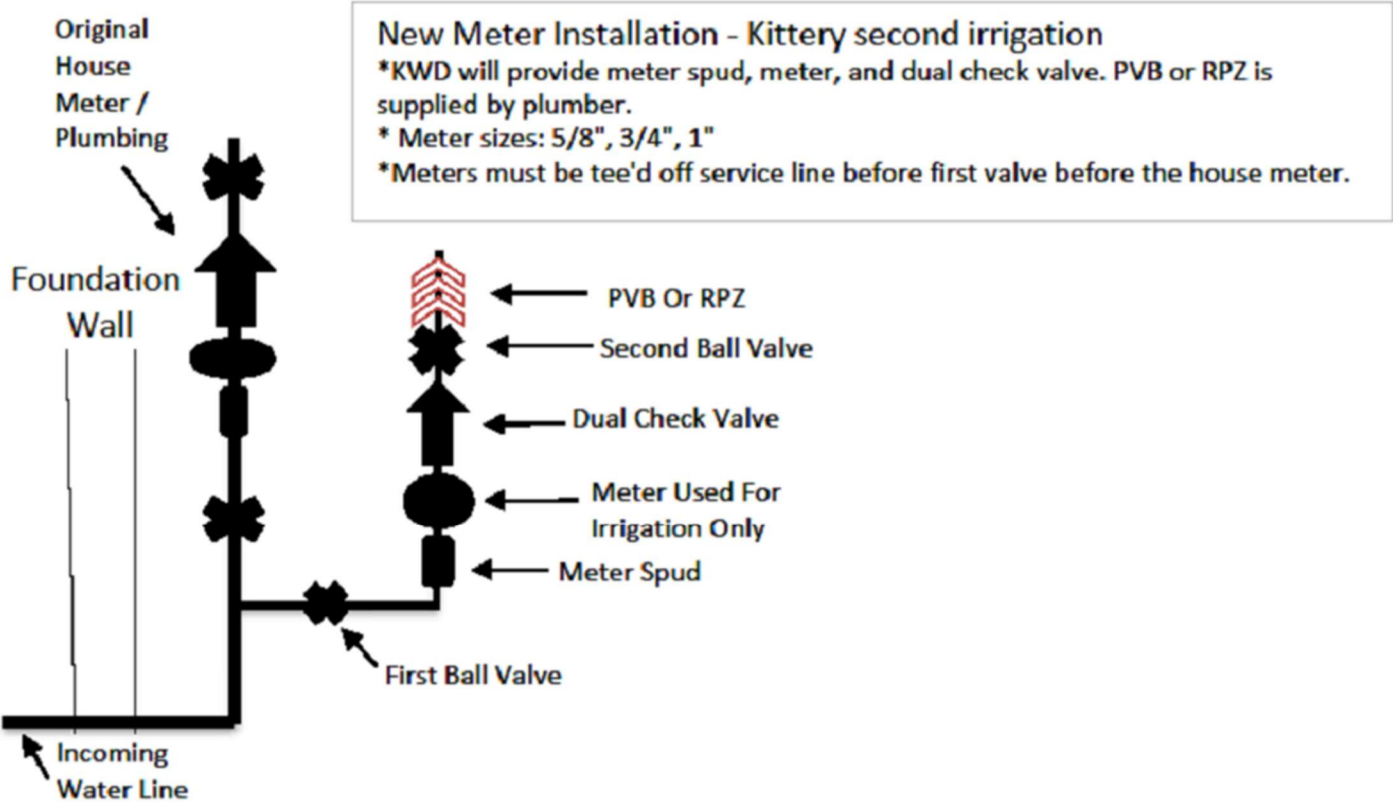

# KITTERY WATER DISTRICT

## WATER LINE CONSTRUCTION SPECIFICATIONS

APRIL 2026

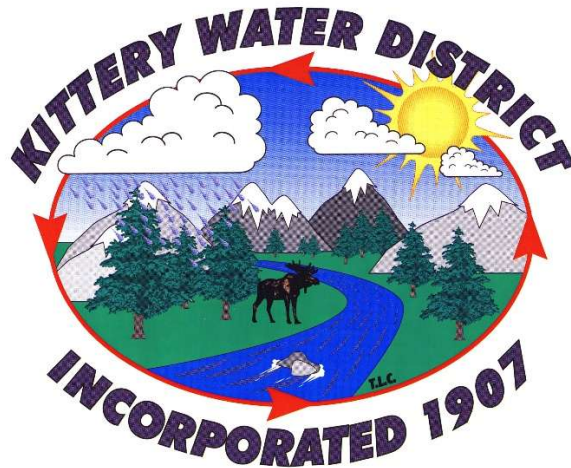

If you have any questions, please call the office at (207) 439-1128 or email at [info@kitterywater.org](mailto:info@kitterywater.org). Your inquiry will be directed to the appropriate staff member, who will follow up as quickly as is possible.

# Table of Contents

Introduction .....	3
Before Beginning Any Work .....	4
Installation Requirements.....	5
Water Line Construction Material Specifications.....	8
Standard 2 - Inch Blow Off Detail .....	11
New Meter Installation – Residential.....	12
New Meter Installation – Commercial.....	13
New Meter Installation – Eliot Deduct .....	14
New Meter Installation- Kittery Second Irrigation.....	15

## **Introduction**

This information is intended to inform and guide homeowners and contractors regarding procedures to follow while working on Kittery Water District (here after KWD) water lines. **This summary does not relieve the owner/contractor of the responsibility for meeting all State and Federal requirements pertaining to the installation of water and sewer lines.**

NOTE: Provided that both the material specifications and installation requirements of the KWD are followed, upon successful installation and testing of the underground and aboveground infrastructure, KWD will accept the ownership of the infrastructure for perpetuity. If the infrastructure is NOT located within the Town or State right-of-way, a Utility Easement will need to be issued to the KWD.

***NOTE: ALL PARTIES ARE STRONGLY ENCOURAGED TO READ THIS BOOKLET AND CALL WITH ANY QUESTIONS PRIOR TO STARTING WORK.***

*This information is subject to revision.*

## **Before Beginning Any Work**

1. The KWD requires **at least one week's notice** before any work can begin. This allows the KWD time to review the project with the owner/contractor and schedule installations and inspections, etc. **The owner/contractor must contact the KWD at (207) 439-1128 prior to beginning work.**
2. Pursuant to Federal Law, the owner/contractor must contact Dig Safe at 811, or 1-888-344-7233 at least three (3) working days prior to the date work is scheduled to begin. A Dig Safe Project Number is required prior to excavation.
3. The owner/contractor shall not operate any hydrants, valves or curb stops that are the property of the KWD, without the expressed permission of the KWD.
4. The owner/contractor shall be responsible for notifying all users/property owners affected, prior to shutting off any services. Appropriate agencies shall also be notified.

# **Installation Requirements**

## **INSPECTION SERVICES:**

Installation inspections will be performed by the District or its representative and paid for by the Developer or Contractor. Full time inspections will be performed by the District or its representative at the jobbing hourly rate. Inspections will be performed during regular business hours 7:00 am – 3:00 pm, Monday – Friday, unless a prior request is issued and approved by the KWD.

## **BEDDING AND BACKFILL:**

- Ledge must be fully excavated a minimum of 12” below and 12” on either side of the pipe.
- A Minimum of 6” of clean sand bedding under the pipe and 12” on either side of the pipe is required.
- Pipe Bedding – AWWA C600 Pipe Laying Sec. 4 standards shall be followed for the installations of water mains and appurtenances. Trenches shall be flat bottomed, with 6” of compacted clean sand beneath and 12” above the pipe. Where ledge is encountered, 12” of compacted clean sand shall be installed beneath the pipe. The trench will be kept dewatered during pipe laying.  
The pipe bedding shall be clean granular sand, free from organic matter, frozen material or any other objectionable material and shall meet the following requirement: 100% passing a 2” sieve.
- Stone Dust is NOT an acceptable substitute for sand.
- A Minimum of 12” of compacted sand above the pipe is required. Compaction can be accomplished by either the excavator bucket or a mechanical compactor.
- The remainder of the trench is to have compacted backfill material pre-approved by the District or its representative. Compaction of this material must be by a mechanical compactor.
- Minimum earth cover over the top of the pipe is 5’-0” (top of pipe to finish grade).
- Locking Tyton / Fastite gaskets shall be installed in the last 3 sections of pipe that is assembled before installing the blow-off assembly.
- The Blow-Off assembly will require that an MJ Tap Cap be installed which will require a spigot end of the pipe. (additional details below).
- Field cutting of pipe is not allowed within 3 feet of the bell of the pipe, unless the nominal O.D. of the pipe is maintained.

## **BLOW-OFF INSTALLATION (SEE DETAIL SHEETS):**

- High density polyethylene (H.D.P.E.) blow-offs are fabricated by KWD (time and material rates apply), and installed by the contractor.
- Valve shall be 2” ball valve, Riser shall be 2” H.D.P.E. plastic pipe.
- Contractor is responsible for backfilling once the Blow-Off and thrust blocks are installed.
- Sand backfill is required from the base of the valve and riser pipe to the top of the ground.
- Care must be taken not to dig beyond the blow-off installation area, such that thrust blocks can be set against undisturbed soil.
- 26” top flange valve box top sections and covers are to be installed over all Blow-Off assemblies, over the service box and over the riser pipe.

### **SERVICES LINE INSTALLATIONS:**

- Upon completion of the water main, and a passing pressure test, installation of services may be proceed.
- On Ductile mains, 1” direct taps will be performed, to a 1” cc Corp, to 1” “K” Copper Service Line, to a 1” Ballvalve Curb stop. The Curb stop will have a 36” s.s. Service Rod and a 4.5’-5.5’ Service Box. A Bibby with Cover labeled “Water” will be installed over the Service Box.
- On HDPE mains, 1” Service Saddles will be installed prior to tapping the main. A 1” cc Corp, to 1” CTS plastic Service Line, to a 1” Ballvalve Curb stop. The Curb stop will have a 36” s.s. Service Rod and a 4.5’-5.5’ Service Box. Tracer wire will be installed to the CTS line. A 6” top flange valve box top section with Cover labeled “WATER” will be installed over the Service Box.
- Clean sand bedding is also required 6” below the copper tubing and 12” to the sides and above. Sand backfill is also required around the service box, from the foot piece to the cap.
- Services that reach or exceed 150 feet from the curb stop will require a meter vault to be installed.

### **TEST SERVICE / CHLORINATION TAP:**

The KWD or Contractor shall install a 1” corporation and a CTS plastic riser with a 1” curb stop cnpj x feip, on the first length of water main that is installed, as close to the mainline valve as is practical. Upon successful completion of a pressure test, chlorination and a negative bacteria test, the Contractor shall excavate to allow removal of the test service and installation of a brass plug by either KWD or the Contractor (time and material rates apply).

### **FIRE HYDRANT INSTALLATIONS:**

- The traffic break flange of the hydrant shall not be less than 2” above the finish grade, nor more than 6” above the finish grade.
- Sand backfill is required around the barrel of the hydrant, from the shoe to the ground’s surface.
- Valve anchoring tees are to be used for all hydrant installations and lateral water mains.
- Marker poles will be provided by the District and installed by the contractor in the appropriate location (material rates apply).

### **WATER MAIN ACCEPTANCE POLICY:**

- The newly installed water main will be filled, flushed, hydrostatically tested and chlorinated by the contractor.
- A negative bacteria result is needed before the water is used for any reason. The contractor or KWD will take this sample and have it analyzed.
- An as-built drawing of the water main installation performed by a licensed surveyor or engineer is required before acceptance of the main by KWD.
- Receipt of an electronic version of the project plan.
- Acknowledgement and execution of any agreements (fire protection lines, fire hydrants, etc.).
- Execution of an Easement to the KWD, for any mains installed in non-public right of ways. This includes both the drafting and recording of the Easement.
- Payment shall be made to KWD for all invoiced services and materials.

## **METERS:**

- Meters are both supplied and installed by KWD (time and material rates apply).
- A sketch is available from the District, outlining the required plumbing setup to receive the meter.
- Type “L” Copper should be used in the installation.

## **NOTES:**

- All materials that are installed are to be made in the USA or Canada, unless otherwise approved by the KWD.
- Material Submittal Sheets (Cut Sheets) shall be submitted to the KWD for approvable prior purchasing the materials.
- Inspection and service work performed by KWD will be billed at the District’s current time and material rates. Services provided by a third party will be billed at their rate.
- The horizontal distance between water and sewer lines shall be a minimum of 10 feet. Anytime a sewer line crosses above a water main, one full section of typical sewer pipe must be replaced with a full section of SDR-21 quality pipe. The full section of SDR-21 pipe shall be centered upon the crossing to maximize joint distance from the watermain and shall have a minimum clearance of 18” above the watermain.
- During new construction groundwork, the Owner / Contractor is responsible for protecting any service or meter that may be in danger of freezing. Associated damage repair costs will be the responsibility of the Owner / Contractor.
- The installation of H.D.P.E. main and CTS Plastic service lines will require the installation of Copper Head Brand tracing wire and Snake Bite Brand connectors. The KWD has very specific requirements for the installation of the tracer wire. The on-site inspector will provide detailed guidance at the time of installation.
- GPK Products, Inc. Schedule 40 x SDR-35 G “No Stop” adaptors must be used for all SDR-35 to SDR-21 connections. Connections of SDR-21 to other types of sewer pipe shall use solid couplings. Flexible couplings will NOT be permitted.

# **Water Line Construction Material Specifications**

## **WATER MAIN:**

- Ductile Iron
- Class 52 thickness
- Tyton / Fastite joint
- Double cement lined
- Zinc coated

## **ALTERNATE WATER MAIN MATERIAL:**

- High Density Polyethylene (H.D.P.E.)
- SDR 11
- Butt Fusion / Electrofusion Couplings
- Blue Stripe
- Copper Head Brand tracer wire is required on the main and all laterals

## **DUCTILE IRON FITTINGS:**

- Class 350
- Made in the USA or Canada

## **DUCTILE IRON GATE VALVES:**

- 250 P.S.I. working pressure
- Open left
- Resilient wedge
- Valves 16" or greater must be Horizontal with Bevel Gear
- Stainless steel nuts and bolts
- Stainless steel or bronze operating nut
- Valve centering rings are required
- Mud plugs are required

## **FIRE HYDRANTS:**

- AFC Waterous Pacer WB 67
- Clow Medallion
- Kennedy Valve Guardian K81-D
- Open left
- Non draining barrel

## **SERVICE BOXES:**

- 4 ½' - 5 ½' height, cap with rope thread and pentagon nut

**VALVE BOXES:**

- Cast iron
- 36” top flange
- 36” bottom base belled (minimum length)
- 5 ¼” diameter
- Drop in cover with pick hole with the word “WATER” cast in the cover
- Made in the USA or Canada

**CORPORATIONS:**

- Minimum size 1” for residential
- Mac Pac compression style nut
- Ball construction
- AY McDonald or Ford brand
- CC thread type

**CURB STOPS:**

- Minimum size 1” for residential
- Mac Pac compression style nut
- Ball construction
- AY McDonald or Ford brand

**SERVICE LINES:**

- Service lines shall be K-copper tubing
- Minimum size of tubing is 1”
- CTS Plastic tubing may be used only when installing an H.D.P.E. main
- ALL service boxes are to be protected using a 5 ¼” x 6” valve box top extension with the cover stamped “WATER”

**STAINLESS STEEL SERVICE RODS:**

- 5/8” x 36” long, with Brass Cotter Pins

**TAPPING SLEEVE:**

- Series 304 stainless steel
- Ductile iron or stainless steel welded flange
- Size on size taps are NOT permitted on cast iron water mains

**RETAINER GLANDS:**

- Romac grip ring brand (R-Blue T-Bolts and nuts required)
- MJ Field Lok brand (R-Blue T-Bolts and nuts required)
- MEGA Lug brand (R-Blue T-Bolts and nuts required)

**SERVICE SADDLES:**

- Ductile Iron body
- Nylon coated body
- Double stainless steel straps
- Electrofusion service saddles with cc threads are required when using H.D.P.E. pipe



**2" Female Poly  
Cam Fitting with  
Plug, Valve Box  
Top Section and  
Cover.**

**KWD to provide 2" SDR  
Riser Pipe, and the  
Contractor will provide  
all other fittings per  
KWD detail**

**2" SDR 11 HDPE  
Riser (provided  
by the KWD)**

**2" Male Poly Cam  
Fitting, 2" Elbow, 2"  
x 12" Nipple, 2" FE x  
FE ball valve curb  
stop, 2" x 6" Nipple,  
36" stainless steel  
rod, service box,  
Valve Box Top  
Section and Cover.**

**KITTERY WATER DISTRICT**  
**Standard 2 - Inch Blow Off Detail**

**This is a parts list beginning at the tapped MJ Cap or Plug:**

- 2" x 6" Brass Nipple
- 2" FE x FE Ball Valve Curb Stop
- 2" x 12" Brass Nipple
- 2" Brass Elbow
- 2" Male Poly Cam \*
- 2" SDR11 H.D.P.E. Pipe \*
- 2" Female Poly Cam \*
- 2" Brass Plug

**Also: After the assembly is installed:**

- Service Box Foot Piece
- Service Box (4' - 6" x 5' - 6")
- 36" x 5/8" Diameter Stainless Steel Service Rod
- Valve Box Cover (2)
- 26" Valve Box Top Section (2)

\* Riser Pipe is welded to the specified length by the Kittery Water District

## New Meter Installation – Residential

### New Meter Installation - Residential

\*KWD will provide meter spud, meter, and dual check valve.  
Meter sizes: 5/8", 3/4", 1" (Determined by water usage)

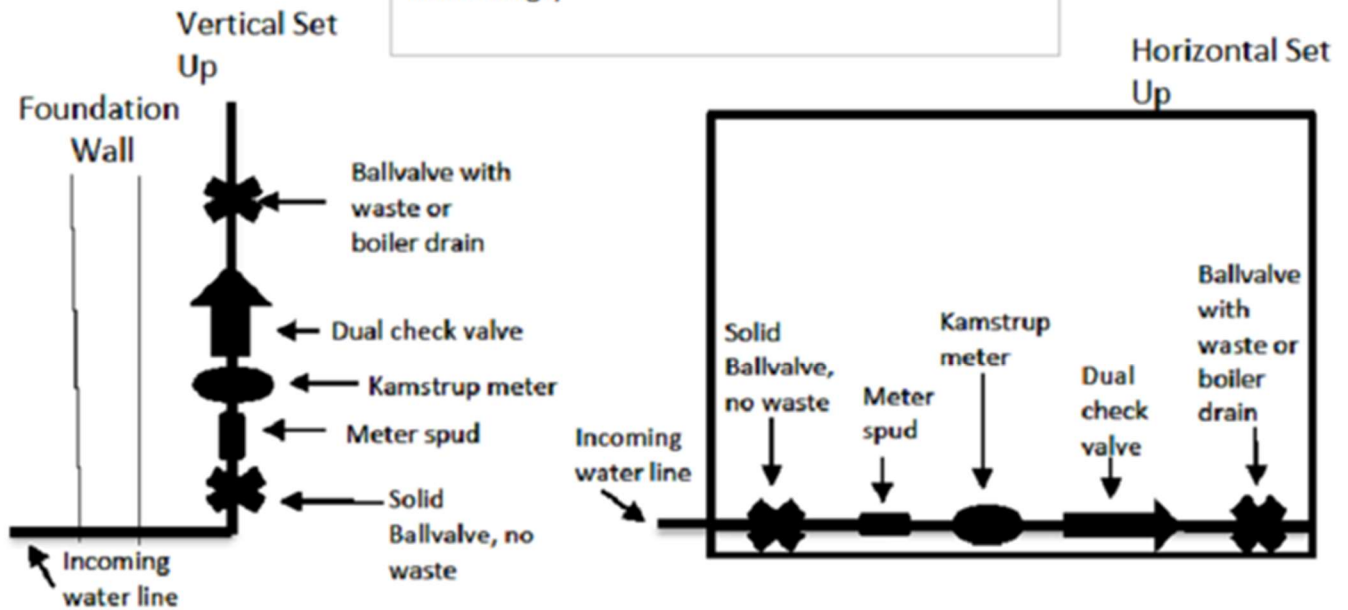

## New Meter Installation – Commercial

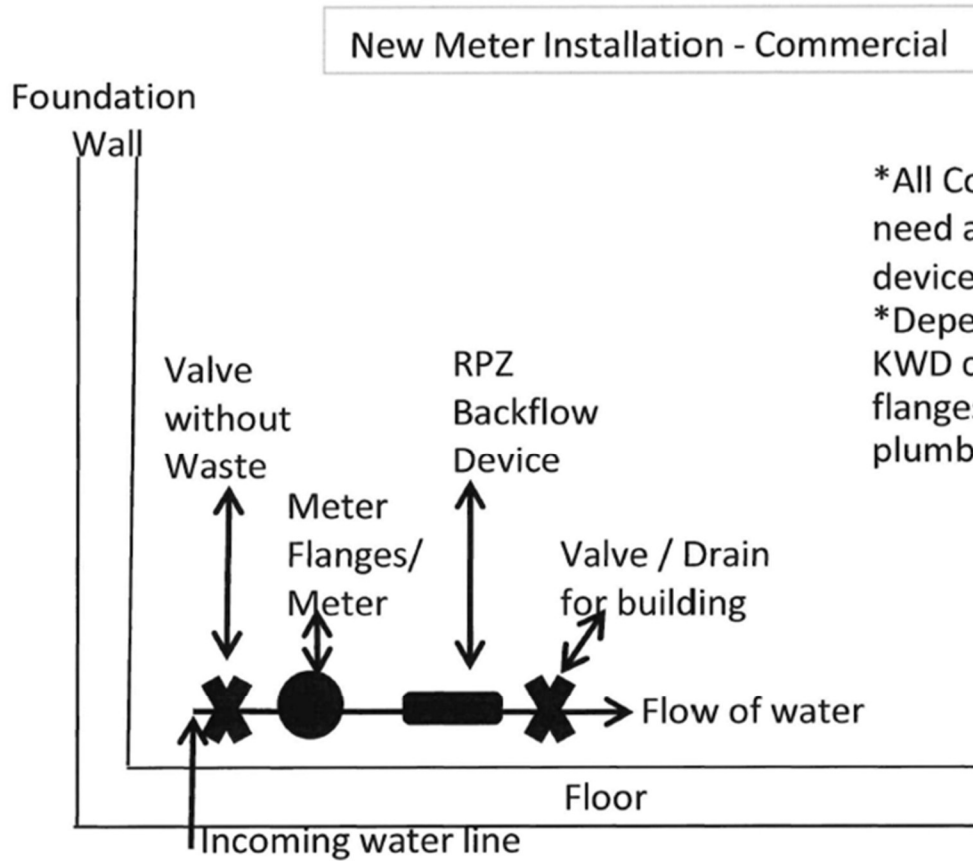

\*All Commercial properties need a testable RPZ backflow device.

\*Depending on size of meter, KWD can provide different flanges or tail pieces for the plumber.

## New Meter Installation – Eliot Deduct

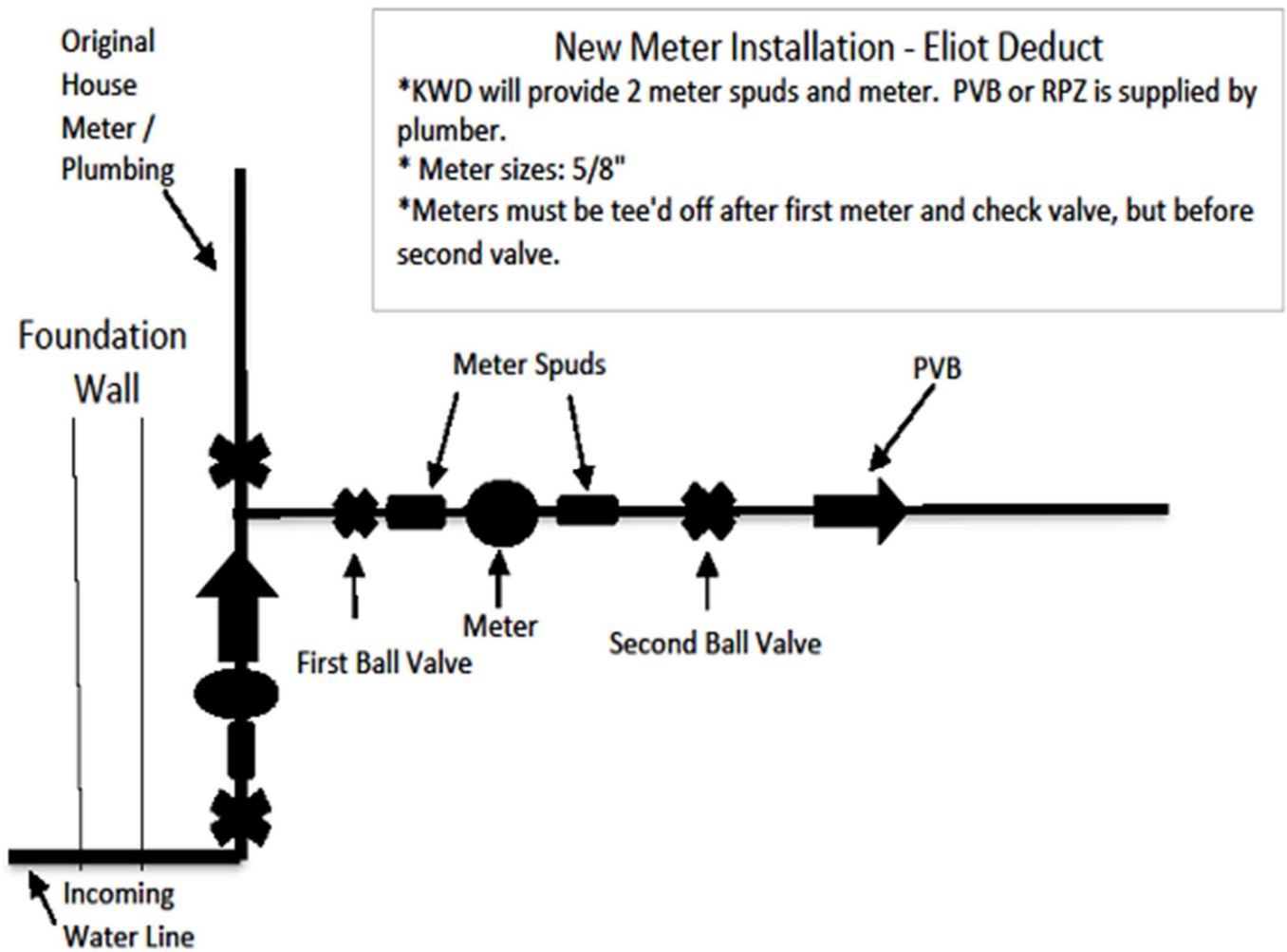

# New Meter Installation - Kittery Second Irrigation

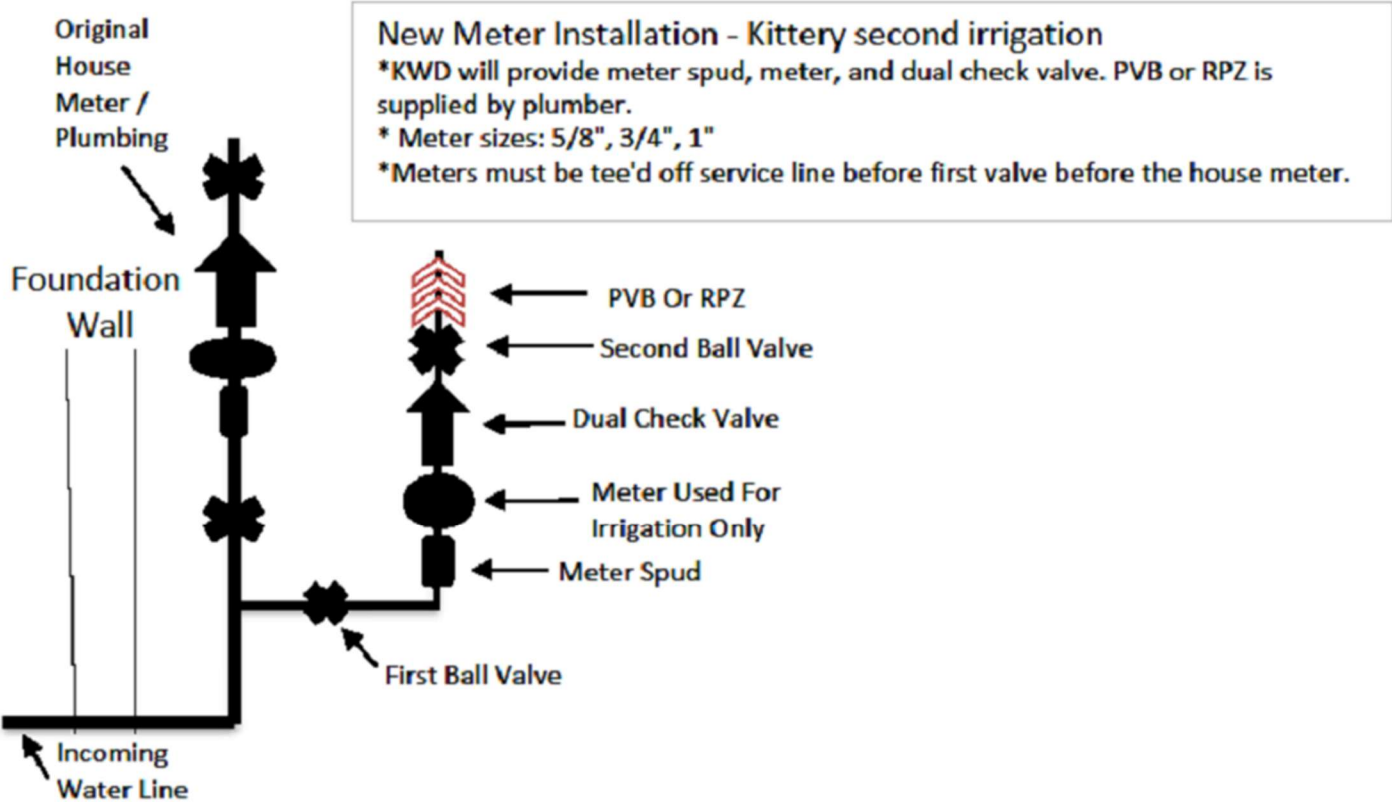

# KITTERY WATER DISTRICT

## WATER LINE CONSTRUCTION SPECIFICATIONS

APRIL 2026



If you have any questions, please call the office at (207) 439-1128 or email at [info@kitterywater.org](mailto:info@kitterywater.org). Your inquiry will be directed to the appropriate staff member, who will follow up as quickly as is possible.

# Table of Contents

Introduction .....	3
Before Beginning Any Work .....	4
Installation Requirements.....	5
Water Line Construction Material Specifications.....	8
Standard 2 - Inch Blow Off Detail .....	11
New Meter Installation – Residential.....	12
New Meter Installation – Commercial.....	13
New Meter Installation – Eliot Deduct .....	14
New Meter Installation- Kittery Second Irrigation.....	15

## **Introduction**

This information is intended to inform and guide homeowners and contractors regarding procedures to follow while working on Kittery Water District (here after KWD) water lines. **This summary does not relieve the owner/contractor of the responsibility for meeting all State and Federal requirements pertaining to the installation of water and sewer lines.**

NOTE: Provided that both the material specifications and installation requirements of the KWD are followed, upon successful installation and testing of the underground and aboveground infrastructure, KWD will accept the ownership of the infrastructure for perpetuity. If the infrastructure is NOT located within the Town or State right-of-way, a Utility Easement will need to be issued to the KWD.

***NOTE: ALL PARTIES ARE STRONGLY ENCOURAGED TO READ THIS BOOKLET AND CALL WITH ANY QUESTIONS PRIOR TO STARTING WORK.***

*This information is subject to revision.*

## **Before Beginning Any Work**

1. The KWD requires **at least one week's notice** before any work can begin. This allows the KWD time to review the project with the owner/contractor and schedule installations and inspections, etc. **The owner/contractor must contact the KWD at (207) 439-1128 prior to beginning work.**
2. Pursuant to Federal Law, the owner/contractor must contact Dig Safe at 811, or 1-888-344-7233 at least three (3) working days prior to the date work is scheduled to begin. A Dig Safe Project Number is required prior to excavation.
3. The owner/contractor shall not operate any hydrants, valves or curb stops that are the property of the KWD, without the expressed permission of the KWD.
4. The owner/contractor shall be responsible for notifying all users/property owners affected, prior to shutting off any services. Appropriate agencies shall also be notified.

## **Installation Requirements**

### **INSPECTION SERVICES:**

Installation inspections will be performed by the District or its representative and paid for by the Developer or Contractor. Full time inspections will be performed by the District or its representative at the jobbing hourly rate. Inspections will be performed during regular business hours 7:00 am – 3:00 pm, Monday – Friday, unless a prior request is issued and approved by the KWD.

### **BEDDING AND BACKFILL:**

- Ledge must be fully excavated a minimum of 12” below and 12” on either side of the pipe.
- A Minimum of 6” of clean sand bedding under the pipe and 12” on either side of the pipe is required.
- Pipe Bedding – AWWA C600 Pipe Laying Sec. 4 standards shall be followed for the installations of water mains and appurtenances. Trenches shall be flat bottomed, with 6” of compacted clean sand beneath and 12” above the pipe. Where ledge is encountered, 12” of compacted clean sand shall be installed beneath the pipe. The trench will be kept dewatered during pipe laying.  
The pipe bedding shall be clean granular sand, free from organic matter, frozen material or any other objectionable material and shall meet the following requirement: 100% passing a 2” sieve.
- Stone Dust is NOT an acceptable substitute for sand.
- A Minimum of 12” of compacted sand above the pipe is required. Compaction can be accomplished by either the excavator bucket or a mechanical compactor.
- The remainder of the trench is to have compacted backfill material pre-approved by the District or its representative. Compaction of this material must be by a mechanical compactor.
- Minimum earth cover over the top of the pipe is 5’-0” (top of pipe to finish grade).
- Locking Tyton / Fastite gaskets shall be installed in the last 3 sections of pipe that is assembled before installing the blow-off assembly.
- The Blow-Off assembly will require that an MJ Tap Cap be installed which will require a spigot end of the pipe. (additional details below).
- Field cutting of pipe is not allowed within 3 feet of the bell of the pipe, unless the nominal O.D. of the pipe is maintained.

### **BLOW-OFF INSTALLATION (SEE DETAIL SHEETS):**

- High density polyethylene (H.D.P.E.) blow-offs are fabricated by KWD (time and material rates apply), and installed by the contractor.
- Valve shall be 2” ball valve, Riser shall be 2” H.D.P.E. plastic pipe.
- Contractor is responsible for backfilling once the Blow-Off and thrust blocks are installed.
- Sand backfill is required from the base of the valve and riser pipe to the top of the ground.
- Care must be taken not to dig beyond the blow-off installation area, such that thrust blocks can be set against undisturbed soil.
- 26” top flange valve box top sections and covers are to be installed over all Blow-Off assemblies, over the service box and over the riser pipe.

### **SERVICES LINE INSTALLATIONS:**

- Upon completion of the water main, and a passing pressure test, installation of services may be proceed.
- On Ductile mains, 1" direct taps will be performed, to a 1" cc Corp, to 1" "K" Copper Service Line, to a 1" Ballvalve Curb stop. The Curb stop will have a 36" s.s. Service Rod and a 4.5'-5.5' Service Box. A Bibby with Cover labeled "Water" will be installed over the Service Box.
- On HDPE mains, 1" Service Saddles will be installed prior to tapping the main. A 1" cc Corp, to 1" CTS plastic Service Line, to a 1" Ballvalve Curb stop. The Curb stop will have a 36" s.s. Service Rod and a 4.5'-5.5' Service Box. Tracer wire will be installed to the CTS line. A 6" top flange valve box top section with Cover labeled "WATER" will be installed over the Service Box.
- Clean sand bedding is also required 6" below the copper tubing and 12" to the sides and above. Sand backfill is also required around the service box, from the foot piece to the cap.
- Services that reach or exceed 150 feet from the curb stop will require a meter vault to be installed.

### **TEST SERVICE / CHLORINATION TAP:**

The KWD or Contractor shall install a 1" corporation and a CTS plastic riser with a 1" curb stop cnpj x feip, on the first length of water main that is installed, as close to the mainline valve as is practical. Upon successful completion of a pressure test, chlorination and a negative bacteria test, the Contractor shall excavate to allow removal of the test service and installation of a brass plug by either KWD or the Contractor (time and material rates apply).

### **FIRE HYDRANT INSTALLATIONS:**

- The traffic break flange of the hydrant shall not be less than 2" above the finish grade, nor more than 6" above the finish grade.
- Sand backfill is required around the barrel of the hydrant, from the shoe to the ground's surface.
- Valve anchoring tees are to be used for all hydrant installations and lateral water mains.
- Marker poles will be provided by the District and installed by the contractor in the appropriate location (material rates apply).

### **WATER MAIN ACCEPTANCE POLICY:**

- The newly installed water main will be filled, flushed, hydrostatically tested and chlorinated by the contractor.
- A negative bacteria result is needed before the water is used for any reason. The contractor or KWD will take this sample and have it analyzed.
- An as-built drawing of the water main installation performed by a licensed surveyor or engineer is required before acceptance of the main by KWD.
- Receipt of an electronic version of the project plan.
- Acknowledgement and execution of any agreements (fire protection lines, fire hydrants, etc.).
- Execution of an Easement to the KWD, for any mains installed in non-public right of ways. This includes both the drafting and recording of the Easement.
- Payment shall be made to KWD for all invoiced services and materials.

## **METERS:**

- Meters are both supplied and installed by KWD (time and material rates apply).
- A sketch is available from the District, outlining the required plumbing setup to receive the meter.
- Type “L” Copper should be used in the installation.

## **NOTES:**

- All materials that are installed are to be made in the USA or Canada, unless otherwise approved by the KWD.
- Material Submittal Sheets (Cut Sheets) shall be submitted to the KWD for approvable prior purchasing the materials.
- Inspection and service work performed by KWD will be billed at the District’s current time and material rates. Services provided by a third party will be billed at their rate.
- The horizontal distance between water and sewer lines shall be a minimum of 10 feet. Anytime a sewer line crosses above a water main, one full section of typical sewer pipe must be replaced with a full section of SDR-21 quality pipe. The full section of SDR-21 pipe shall be centered upon the crossing to maximize joint distance from the watermain and shall have a minimum clearance of 18” above the watermain.
- During new construction groundwork, the Owner / Contractor is responsible for protecting any service or meter that may be in danger of freezing. Associated damage repair costs will be the responsibility of the Owner / Contractor.
- The installation of H.D.P.E. main and CTS Plastic service lines will require the installation of Copper Head Brand tracing wire and Snake Bite Brand connectors. The KWD has very specific requirements for the installation of the tracer wire. The on-site inspector will provide detailed guidance at the time of installation.
- GPK Products, Inc. Schedule 40 x SDR-35 G “No Stop” adaptors must be used for all SDR-35 to SDR-21 connections. Connections of SDR-21 to other types of sewer pipe shall use solid couplings. Flexible couplings will NOT be permitted.

# **Water Line Construction Material Specifications**

## **WATER MAIN:**

- Ductile Iron
- Class 52 thickness
- Tyton / Fastite joint
- Double cement lined
- Zinc coated

## **ALTERNATE WATER MAIN MATERIAL:**

- High Density Polyethylene (H.D.P.E.)
- SDR 11
- Butt Fusion / Electrofusion Couplings
- Blue Stripe
- Copper Head Brand tracer wire is required on the main and all laterals

## **DUCTILE IRON FITTINGS:**

- Class 350
- Made in the USA or Canada

## **DUCTILE IRON GATE VALVES:**

- 250 P.S.I. working pressure
- Open left
- Resilient wedge
- Valves 16" or greater must be Horizontal with Bevel Gear
- Stainless steel nuts and bolts
- Stainless steel or bronze operating nut
- Valve centering rings are required
- Mud plugs are required

## **FIRE HYDRANTS:**

- AFC Waterous Pacer WB 67
- Clow Medallion
- Kennedy Valve Guardian K81-D
- Open left
- Non draining barrel

## **SERVICE BOXES:**

- 4 ½' - 5 ½' height, cap with rope thread and pentagon nut

**VALVE BOXES:**

- Cast iron
- 36” top flange
- 36” bottom base belled (minimum length)
- 5 ¼” diameter
- Drop in cover with pick hole with the word “WATER” cast in the cover
- Made in the USA or Canada

**CORPORATIONS:**

- Minimum size 1” for residential
- Mac Pac compression style nut
- Ball construction
- AY McDonald or Ford brand
- CC thread type

**CURB STOPS:**

- Minimum size 1” for residential
- Mac Pac compression style nut
- Ball construction
- AY McDonald or Ford brand

**SERVICE LINES:**

- Service lines shall be K-copper tubing
- Minimum size of tubing is 1”
- CTS Plastic tubing may be used only when installing an H.D.P.E. main
- ALL service boxes are to be protected using a 5 ¼” x 6” valve box top extension with the cover stamped “WATER”

**STAINLESS STEEL SERVICE RODS:**

- 5/8” x 36” long, with Brass Cotter Pins

**TAPPING SLEEVE:**

- Series 304 stainless steel
- Ductile iron or stainless steel welded flange
- Size on size taps are NOT permitted on cast iron water mains

**RETAINER GLANDS:**

- Romac grip ring brand (R-Blue T-Bolts and nuts required)
- MJ Field Lok brand (R-Blue T-Bolts and nuts required)
- MEGA Lug brand (R-Blue T-Bolts and nuts required)

**SERVICE SADDLES:**

- Ductile Iron body
- Nylon coated body
- Double stainless steel straps
- Electrofusion service saddles with cc threads are required when using H.D.P.E. pipe



**2" Female Poly Cam Fitting with Plug, Valve Box Top Section and Cover.**

**KWD to provide 2" SDR Riser Pipe, and the Contractor will provide all other fittings per KWD detail**

**2" SDR 11 HDPE Riser (provided by the KWD)**

**2" Male Poly Cam Fitting, 2" Elbow, 2" x 12" Nipple, 2" FE x FE ball valve curb stop, 2" x 6" Nipple, 36" stainless steel rod, service box, Valve Box Top Section and Cover.**

# **KITTERY WATER DISTRICT**

## **Standard 2 - Inch Blow Off Detail**

### **This is a parts list beginning at the tapped MJ Cap or Plug:**

- 2" x 6" Brass Nipple
- 2" FE x FE Ball Valve Curb Stop
- 2" x 12" Brass Nipple
- 2" Brass Elbow
- 2" Male Poly Cam \*
- 2" SDR11 H.D.P.E. Pipe \*
- 2" Female Poly Cam \*
- 2" Brass Plug

### **Also: After the assembly is installed:**

- Service Box Foot Piece
- Service Box (4' - 6" x 5' - 6")
- 36" x 5/8" Diameter Stainless Steel Service Rod
- Valve Box Cover (2)
- 26" Valve Box Top Section (2)

\* Riser Pipe is welded to the specified length by the Kittery Water District

## New Meter Installation – Residential

### New Meter Installation - Residential

\*KWD will provide meter spud, meter, and dual check valve.  
Meter sizes: 5/8", 3/4", 1" (Determined by water usage)

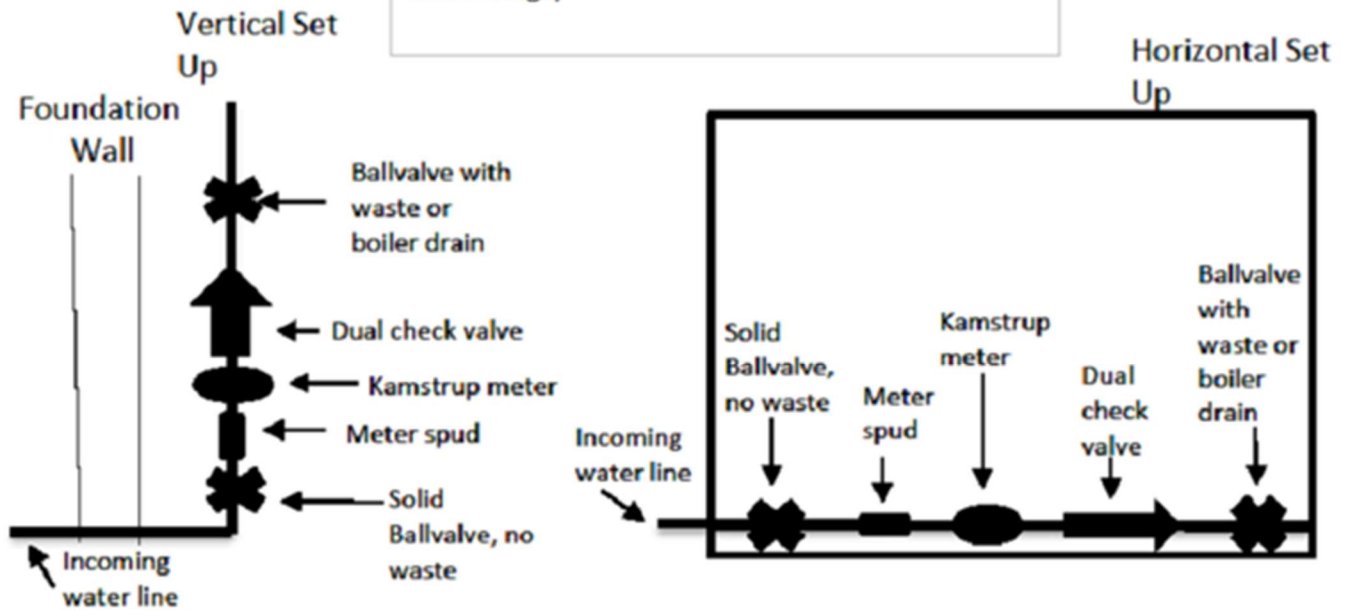

## New Meter Installation – Commercial

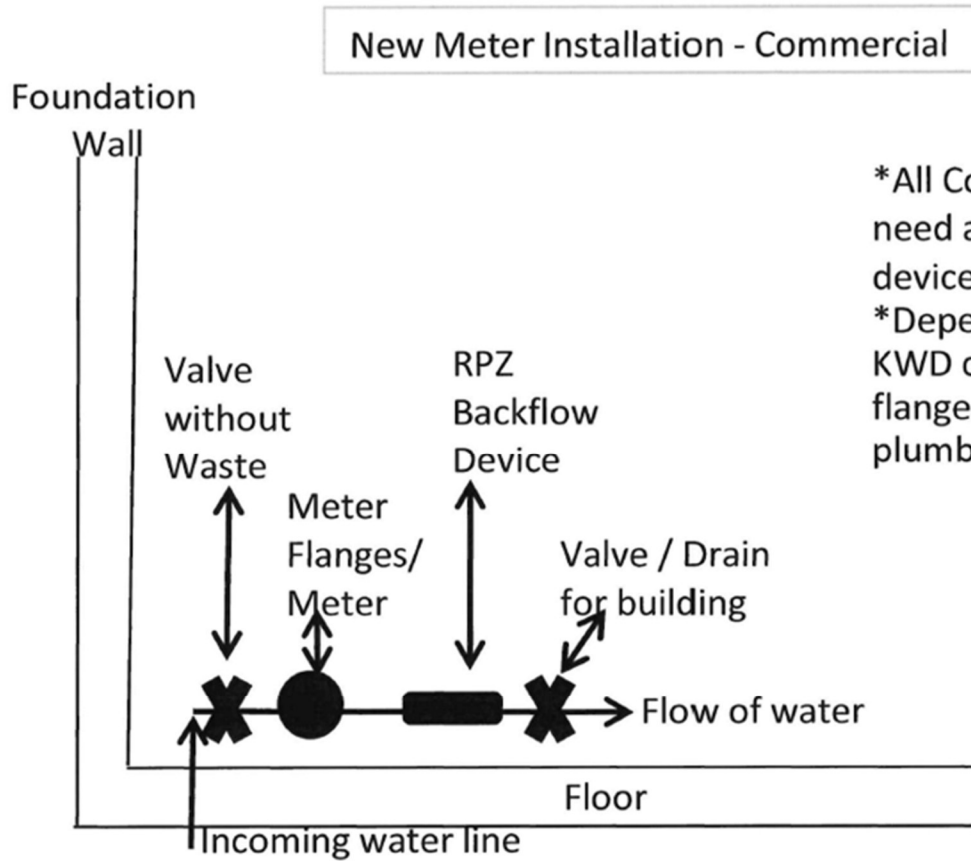

\*All Commercial properties need a testable RPZ backflow device.

\*Depending on size of meter, KWD can provide different flanges or tail pieces for the plumber.

## New Meter Installation – Eliot Deduct

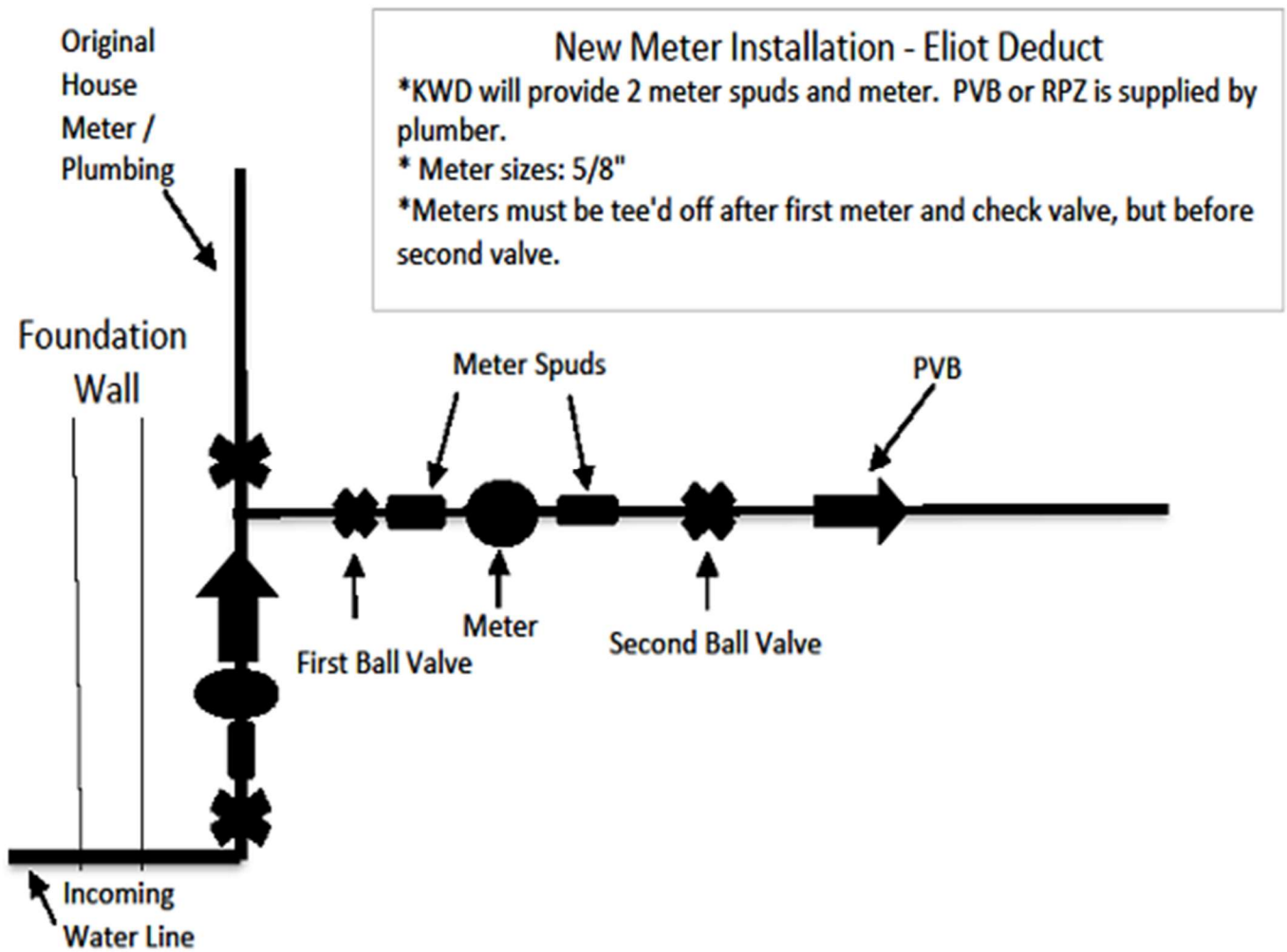

# New Meter Installation - Kittery Second Irrigation

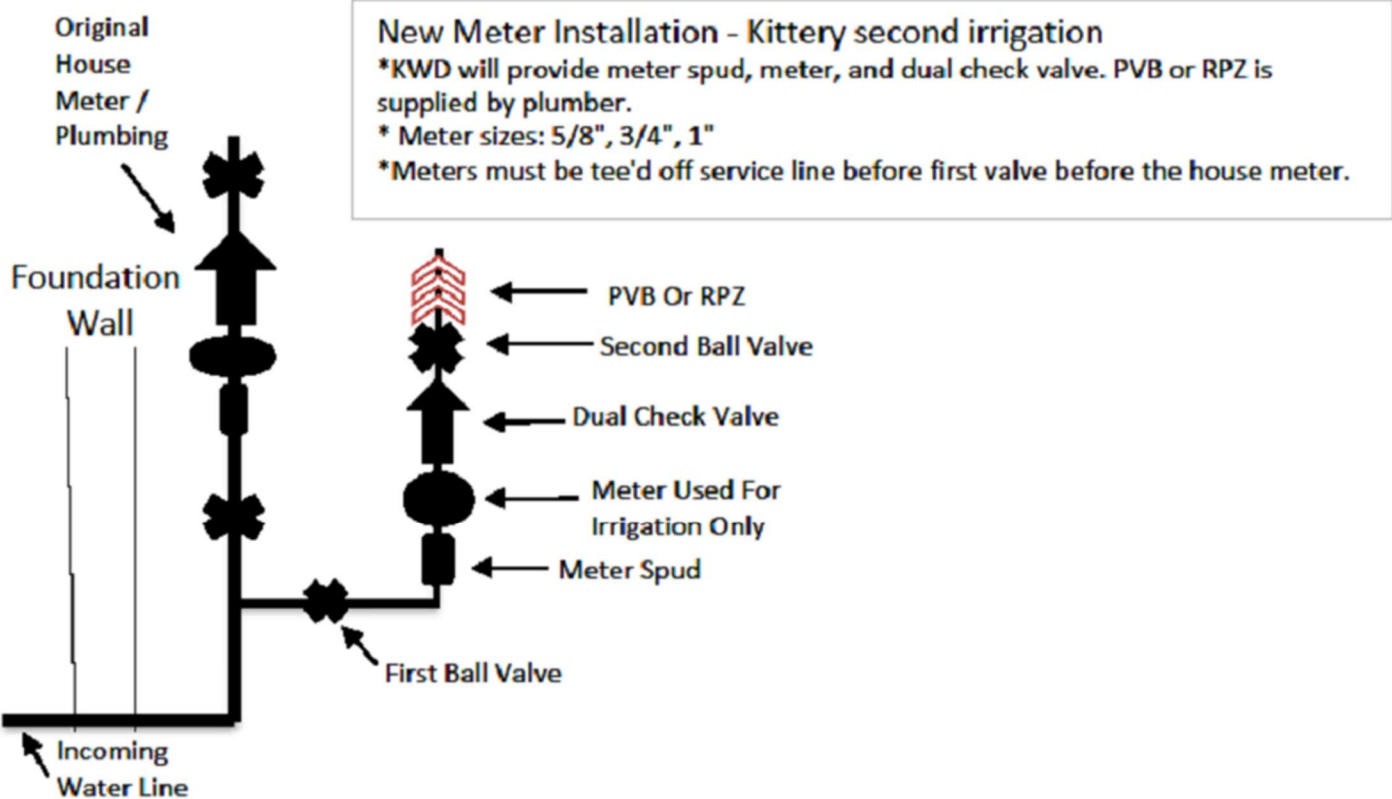

# KITTERY WATER DISTRICT

## WATER LINE CONSTRUCTION SPECIFICATIONS

APRIL 2026



If you have any questions, please call the office at (207) 439-1128 or email at [info@kitterywater.org](mailto:info@kitterywater.org). Your inquiry will be directed to the appropriate staff member, who will follow up as quickly as is possible.

# Table of Contents

Introduction .....	3
Before Beginning Any Work .....	4
Installation Requirements.....	5
Water Line Construction Material Specifications.....	8
Standard 2 - Inch Blow Off Detail .....	11
New Meter Installation – Residential.....	12
New Meter Installation – Commercial.....	13
New Meter Installation – Eliot Deduct .....	14
New Meter Installation- Kittery Second Irrigation.....	15

## **Introduction**

This information is intended to inform and guide homeowners and contractors regarding procedures to follow while working on Kittery Water District (here after KWD) water lines. **This summary does not relieve the owner/contractor of the responsibility for meeting all State and Federal requirements pertaining to the installation of water and sewer lines.**

NOTE: Provided that both the material specifications and installation requirements of the KWD are followed, upon successful installation and testing of the underground and aboveground infrastructure, KWD will accept the ownership of the infrastructure for perpetuity. If the infrastructure is NOT located within the Town or State right-of-way, a Utility Easement will need to be issued to the KWD.

***NOTE: ALL PARTIES ARE STRONGLY ENCOURAGED TO READ THIS BOOKLET AND CALL WITH ANY QUESTIONS PRIOR TO STARTING WORK.***

*This information is subject to revision.*

## **Before Beginning Any Work**

1. The KWD requires **at least one week's notice** before any work can begin. This allows the KWD time to review the project with the owner/contractor and schedule installations and inspections, etc. **The owner/contractor must contact the KWD at (207) 439-1128 prior to beginning work.**
2. Pursuant to Federal Law, the owner/contractor must contact Dig Safe at 811, or 1-888-344-7233 at least three (3) working days prior to the date work is scheduled to begin. A Dig Safe Project Number is required prior to excavation.
3. The owner/contractor shall not operate any hydrants, valves or curb stops that are the property of the KWD, without the expressed permission of the KWD.
4. The owner/contractor shall be responsible for notifying all users/property owners affected, prior to shutting off any services. Appropriate agencies shall also be notified.

# **Installation Requirements**

## **INSPECTION SERVICES:**

Installation inspections will be performed by the District or its representative and paid for by the Developer or Contractor. Full time inspections will be performed by the District or its representative at the jobbing hourly rate. Inspections will be performed during regular business hours 7:00 am – 3:00 pm, Monday – Friday, unless a prior request is issued and approved by the KWD.

## **BEDDING AND BACKFILL:**

- Ledge must be fully excavated a minimum of 12” below and 12” on either side of the pipe.
- A Minimum of 6” of clean sand bedding under the pipe and 12” on either side of the pipe is required.
- Pipe Bedding – AWWA C600 Pipe Laying Sec. 4 standards shall be followed for the installations of water mains and appurtenances. Trenches shall be flat bottomed, with 6” of compacted clean sand beneath and 12” above the pipe. Where ledge is encountered, 12” of compacted clean sand shall be installed beneath the pipe. The trench will be kept dewatered during pipe laying.  
The pipe bedding shall be clean granular sand, free from organic matter, frozen material or any other objectionable material and shall meet the following requirement: 100% passing a 2” sieve.
- Stone Dust is NOT an acceptable substitute for sand.
- A Minimum of 12” of compacted sand above the pipe is required. Compaction can be accomplished by either the excavator bucket or a mechanical compactor.
- The remainder of the trench is to have compacted backfill material pre-approved by the District or its representative. Compaction of this material must be by a mechanical compactor.
- Minimum earth cover over the top of the pipe is 5’-0” (top of pipe to finish grade).
- Locking Tyton / Fastite gaskets shall be installed in the last 3 sections of pipe that is assembled before installing the blow-off assembly.
- The Blow-Off assembly will require that an MJ Tap Cap be installed which will require a spigot end of the pipe. (additional details below).
- Field cutting of pipe is not allowed within 3 feet of the bell of the pipe, unless the nominal O.D. of the pipe is maintained.

## **BLOW-OFF INSTALLATION (SEE DETAIL SHEETS):**

- High density polyethylene (H.D.P.E.) blow-offs are fabricated by KWD (time and material rates apply), and installed by the contractor.
- Valve shall be 2” ball valve, Riser shall be 2” H.D.P.E. plastic pipe.
- Contractor is responsible for backfilling once the Blow-Off and thrust blocks are installed.
- Sand backfill is required from the base of the valve and riser pipe to the top of the ground.
- Care must be taken not to dig beyond the blow-off installation area, such that thrust blocks can be set against undisturbed soil.
- 26” top flange valve box top sections and covers are to be installed over all Blow-Off assemblies, over the service box and over the riser pipe.

### **SERVICES LINE INSTALLATIONS:**

- Upon completion of the water main, and a passing pressure test, installation of services may be proceed.
- On Ductile mains, 1” direct taps will be performed, to a 1” cc Corp, to 1” “K” Copper Service Line, to a 1” Ballvalve Curb stop. The Curb stop will have a 36” s.s. Service Rod and a 4.5’-5.5’ Service Box. A Bibby with Cover labeled “Water” will be installed over the Service Box.
- On HDPE mains, 1” Service Saddles will be installed prior to tapping the main. A 1” cc Corp, to 1” CTS plastic Service Line, to a 1” Ballvalve Curb stop. The Curb stop will have a 36” s.s. Service Rod and a 4.5’-5.5’ Service Box. Tracer wire will be installed to the CTS line. A 6” top flange valve box top section with Cover labeled “WATER” will be installed over the Service Box.
- Clean sand bedding is also required 6” below the copper tubing and 12” to the sides and above. Sand backfill is also required around the service box, from the foot piece to the cap.
- Services that reach or exceed 150 feet from the curb stop will require a meter vault to be installed.

### **TEST SERVICE / CHLORINATION TAP:**

The KWD or Contractor shall install a 1” corporation and a CTS plastic riser with a 1” curb stop cnpj x feip, on the first length of water main that is installed, as close to the mainline valve as is practical. Upon successful completion of a pressure test, chlorination and a negative bacteria test, the Contractor shall excavate to allow removal of the test service and installation of a brass plug by either KWD or the Contractor (time and material rates apply).

### **FIRE HYDRANT INSTALLATIONS:**

- The traffic break flange of the hydrant shall not be less than 2” above the finish grade, nor more than 6” above the finish grade.
- Sand backfill is required around the barrel of the hydrant, from the shoe to the ground’s surface.
- Valve anchoring tees are to be used for all hydrant installations and lateral water mains.
- Marker poles will be provided by the District and installed by the contractor in the appropriate location (material rates apply).

### **WATER MAIN ACCEPTANCE POLICY:**

- The newly installed water main will be filled, flushed, hydrostatically tested and chlorinated by the contractor.
- A negative bacteria result is needed before the water is used for any reason. The contractor or KWD will take this sample and have it analyzed.
- An as-built drawing of the water main installation performed by a licensed surveyor or engineer is required before acceptance of the main by KWD.
- Receipt of an electronic version of the project plan.
- Acknowledgement and execution of any agreements (fire protection lines, fire hydrants, etc.).
- Execution of an Easement to the KWD, for any mains installed in non-public right of ways. This includes both the drafting and recording of the Easement.
- Payment shall be made to KWD for all invoiced services and materials.

## **METERS:**

- Meters are both supplied and installed by KWD (time and material rates apply).
- A sketch is available from the District, outlining the required plumbing setup to receive the meter.
- Type “L” Copper should be used in the installation.

## **NOTES:**

- All materials that are installed are to be made in the USA or Canada, unless otherwise approved by the KWD.
- Material Submittal Sheets (Cut Sheets) shall be submitted to the KWD for approvable prior purchasing the materials.
- Inspection and service work performed by KWD will be billed at the District’s current time and material rates. Services provided by a third party will be billed at their rate.
- The horizontal distance between water and sewer lines shall be a minimum of 10 feet. Anytime a sewer line crosses above a water main, one full section of typical sewer pipe must be replaced with a full section of SDR-21 quality pipe. The full section of SDR-21 pipe shall be centered upon the crossing to maximize joint distance from the watermain and shall have a minimum clearance of 18” above the watermain.
- During new construction groundwork, the Owner / Contractor is responsible for protecting any service or meter that may be in danger of freezing. Associated damage repair costs will be the responsibility of the Owner / Contractor.
- The installation of H.D.P.E. main and CTS Plastic service lines will require the installation of Copper Head Brand tracing wire and Snake Bite Brand connectors. The KWD has very specific requirements for the installation of the tracer wire. The on-site inspector will provide detailed guidance at the time of installation.
- GPK Products, Inc. Schedule 40 x SDR-35 G “No Stop” adaptors must be used for all SDR-35 to SDR-21 connections. Connections of SDR-21 to other types of sewer pipe shall use solid couplings. Flexible couplings will NOT be permitted.

# **Water Line Construction Material Specifications**

## **WATER MAIN:**

- Ductile Iron
- Class 52 thickness
- Tyton / Fastite joint
- Double cement lined
- Zinc coated

## **ALTERNATE WATER MAIN MATERIAL:**

- High Density Polyethylene (H.D.P.E.)
- SDR 11
- Butt Fusion / Electrofusion Couplings
- Blue Stripe
- Copper Head Brand tracer wire is required on the main and all laterals

## **DUCTILE IRON FITTINGS:**

- Class 350
- Made in the USA or Canada

## **DUCTILE IRON GATE VALVES:**

- 250 P.S.I. working pressure
- Open left
- Resilient wedge
- Valves 16" or greater must be Horizontal with Bevel Gear
- Stainless steel nuts and bolts
- Stainless steel or bronze operating nut
- Valve centering rings are required
- Mud plugs are required

## **FIRE HYDRANTS:**

- AFC Waterous Pacer WB 67
- Clow Medallion
- Kennedy Valve Guardian K81-D
- Open left
- Non draining barrel

## **SERVICE BOXES:**

- 4 ½' - 5 ½' height, cap with rope thread and pentagon nut

**VALVE BOXES:**

- Cast iron
- 36” top flange
- 36” bottom base belled (minimum length)
- 5 ¼” diameter
- Drop in cover with pick hole with the word “WATER” cast in the cover
- Made in the USA or Canada

**CORPORATIONS:**

- Minimum size 1” for residential
- Mac Pac compression style nut
- Ball construction
- AY McDonald or Ford brand
- CC thread type

**CURB STOPS:**

- Minimum size 1” for residential
- Mac Pac compression style nut
- Ball construction
- AY McDonald or Ford brand

**SERVICE LINES:**

- Service lines shall be K-copper tubing
- Minimum size of tubing is 1”
- CTS Plastic tubing may be used only when installing an H.D.P.E. main
- ALL service boxes are to be protected using a 5 ¼” x 6” valve box top extension with the cover stamped “WATER”

**STAINLESS STEEL SERVICE RODS:**

- 5/8” x 36” long, with Brass Cotter Pins

**TAPPING SLEEVE:**

- Series 304 stainless steel
- Ductile iron or stainless steel welded flange
- Size on size taps are NOT permitted on cast iron water mains

**RETAINER GLANDS:**

- Romac grip ring brand (R-Blue T-Bolts and nuts required)
- MJ Field Lok brand (R-Blue T-Bolts and nuts required)
- MEGA Lug brand (R-Blue T-Bolts and nuts required)

**SERVICE SADDLES:**

- Ductile Iron body
- Nylon coated body
- Double stainless steel straps
- Electrofusion service saddles with cc threads are required when using H.D.P.E. pipe



**2" Female Poly  
Cam Fitting with  
Plug, Valve Box  
Top Section and  
Cover.**

**KWD to provide 2" SDR  
Riser Pipe, and the  
Contractor will provide  
all other fittings per  
KWD detail**

**2" SDR 11 HDPE  
Riser (provided  
by the KWD)**

**2" Male Poly Cam  
Fitting, 2" Elbow, 2"  
x 12" Nipple, 2" FE x  
FE ball valve curb  
stop, 2" x 6" Nipple,  
36" stainless steel  
rod, service box,  
Valve Box Top  
Section and Cover.**

# **KITTERY WATER DISTRICT**

## **Standard 2 - Inch Blow Off Detail**

### **This is a parts list beginning at the tapped MJ Cap or Plug:**

- 2" x 6" Brass Nipple
- 2" FE x FE Ball Valve Curb Stop
- 2" x 12" Brass Nipple
- 2" Brass Elbow
- 2" Male Poly Cam \*
- 2" SDR11 H.D.P.E. Pipe \*
- 2" Female Poly Cam \*
- 2" Brass Plug

### **Also: After the assembly is installed:**

- Service Box Foot Piece
- Service Box (4' - 6" x 5' - 6")
- 36" x 5/8" Diameter Stainless Steel Service Rod
- Valve Box Cover (2)
- 26" Valve Box Top Section (2)

\* Riser Pipe is welded to the specified length by the Kittery Water District

## New Meter Installation – Residential

### New Meter Installation - Residential

\*KWD will provide meter spud, meter, and dual check valve.  
Meter sizes: 5/8", 3/4", 1" (Determined by water usage)

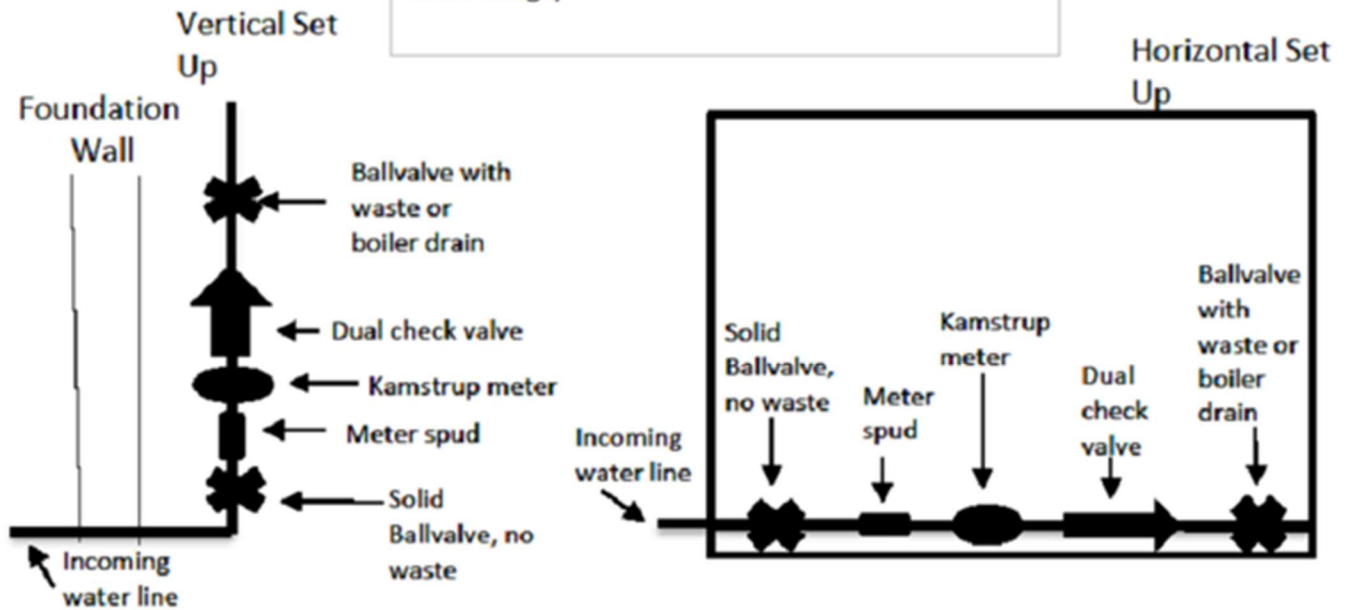

## New Meter Installation – Commercial

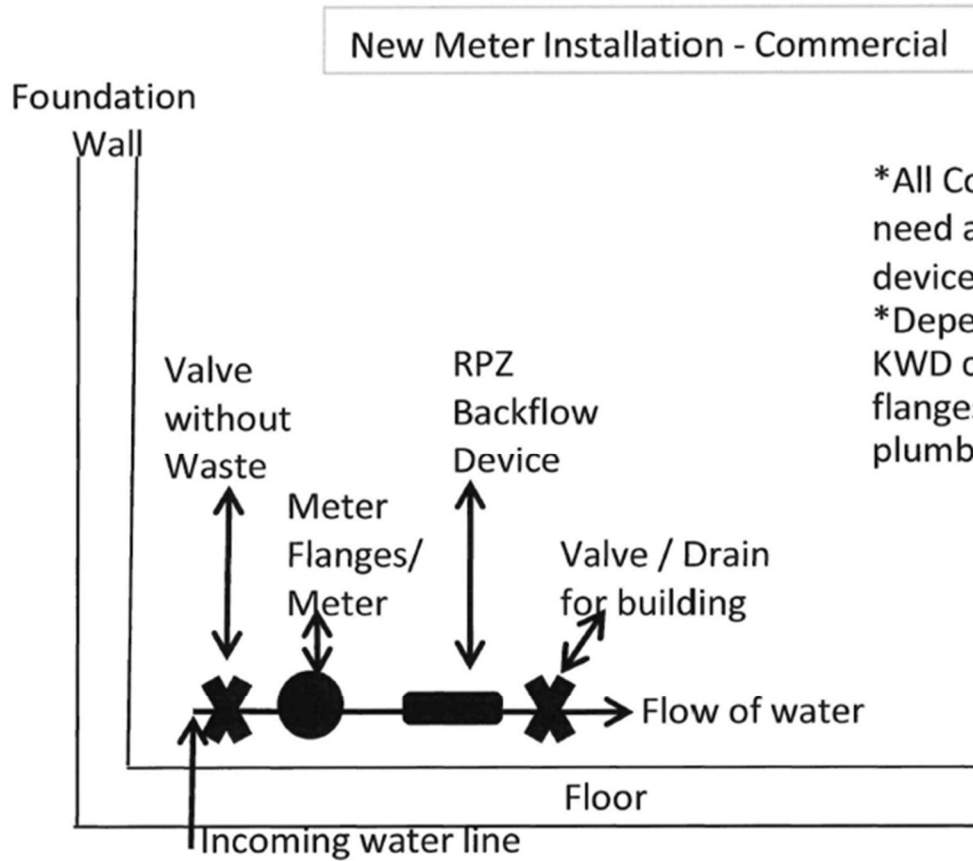

\*All Commercial properties need a testable RPZ backflow device.

\*Depending on size of meter, KWD can provide different flanges or tail pieces for the plumber.

## New Meter Installation – Eliot Deduct

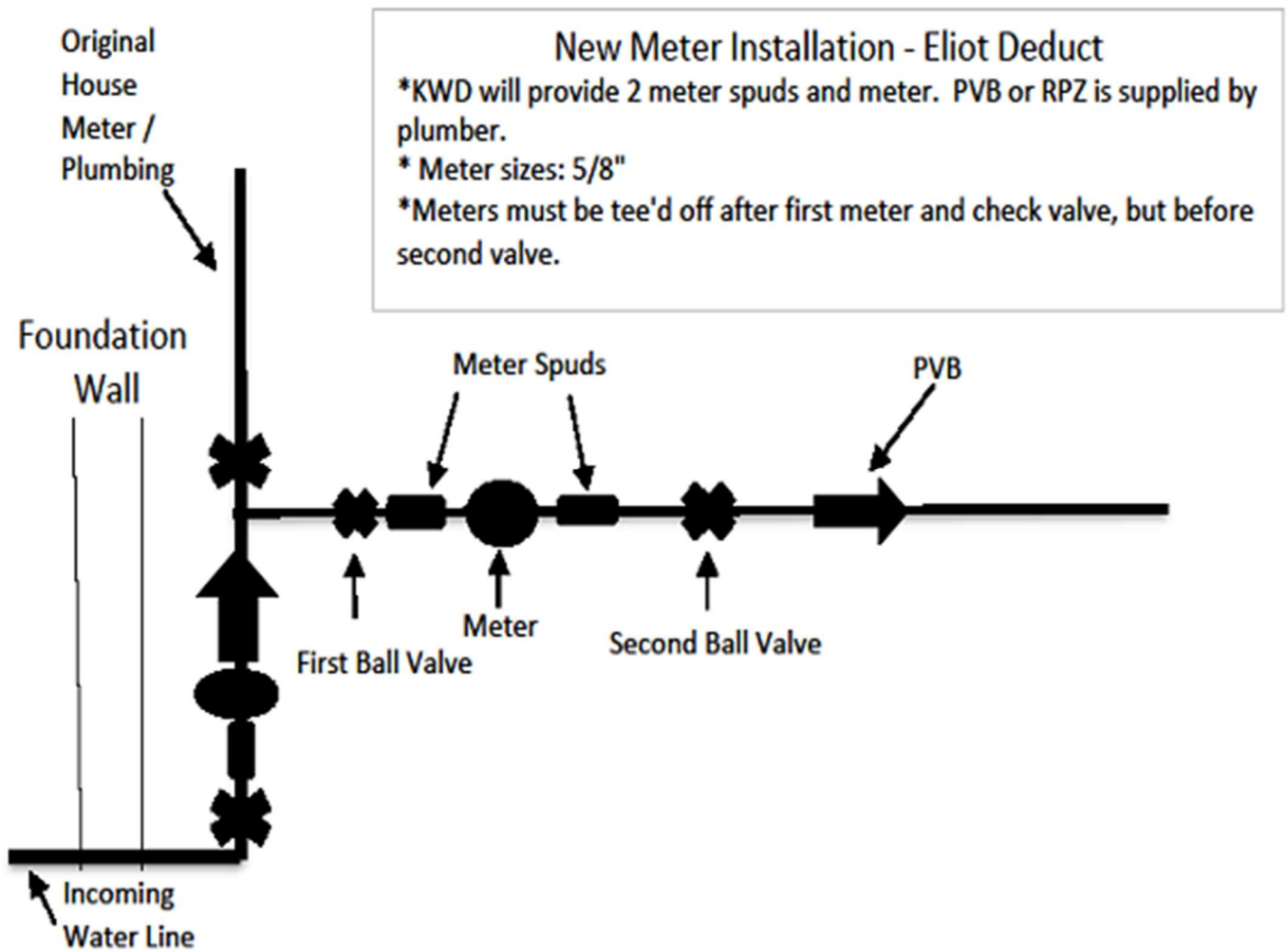

# New Meter Installation - Kittery Second Irrigation

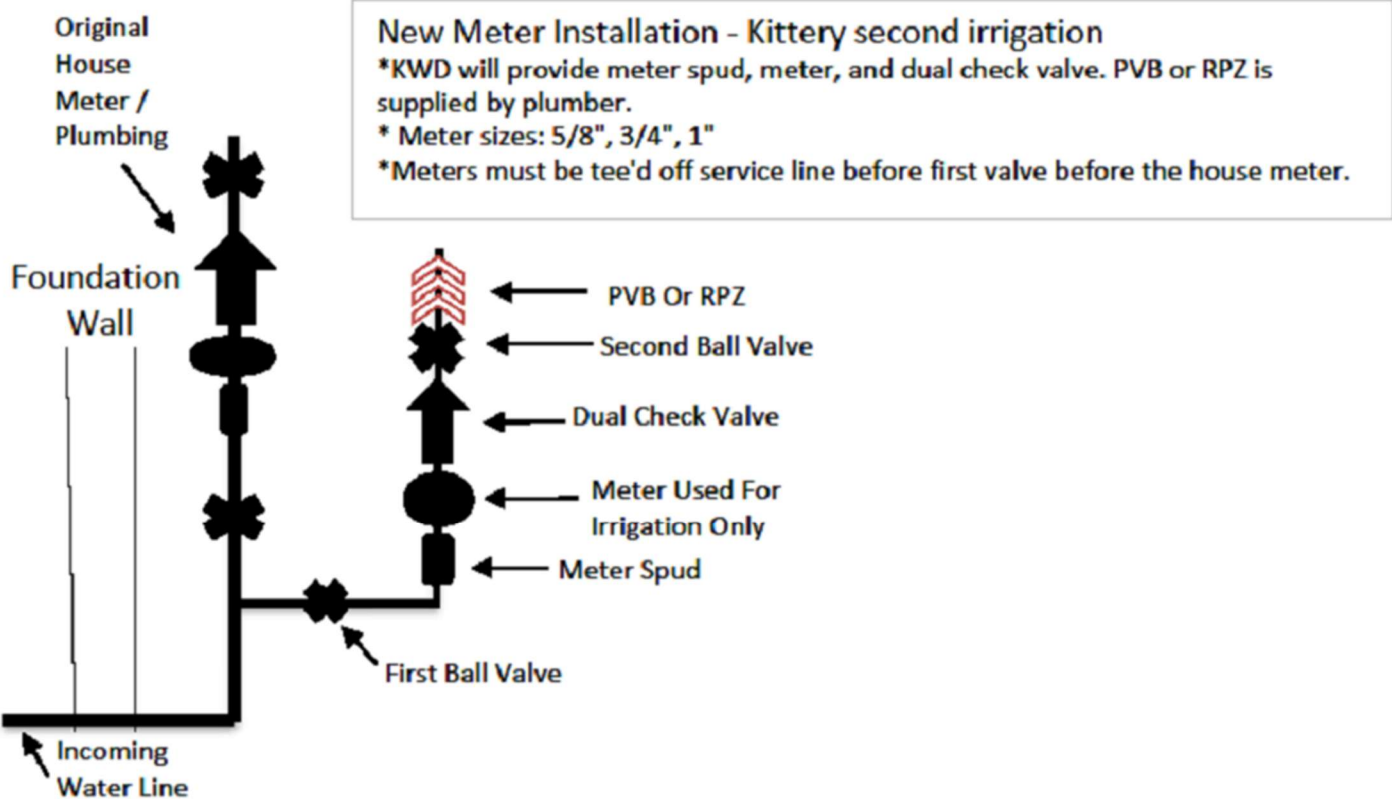

# KITTERY WATER DISTRICT

## WATER LINE CONSTRUCTION SPECIFICATIONS

APRIL 2026



If you have any questions, please call the office at (207) 439-1128 or email at [info@kitterywater.org](mailto:info@kitterywater.org). Your inquiry will be directed to the appropriate staff member, who will follow up as quickly as is possible.

# Table of Contents

Introduction .....	3
Before Beginning Any Work .....	4
Installation Requirements.....	5
Water Line Construction Material Specifications.....	8
Standard 2 - Inch Blow Off Detail .....	11
New Meter Installation – Residential.....	12
New Meter Installation – Commercial.....	13
New Meter Installation – Eliot Deduct .....	14
New Meter Installation- Kittery Second Irrigation.....	15

## **Introduction**

This information is intended to inform and guide homeowners and contractors regarding procedures to follow while working on Kittery Water District (here after KWD) water lines. **This summary does not relieve the owner/contractor of the responsibility for meeting all State and Federal requirements pertaining to the installation of water and sewer lines.**

NOTE: Provided that both the material specifications and installation requirements of the KWD are followed, upon successful installation and testing of the underground and aboveground infrastructure, KWD will accept the ownership of the infrastructure for perpetuity. If the infrastructure is NOT located within the Town or State right-of-way, a Utility Easement will need to be issued to the KWD.

***NOTE: ALL PARTIES ARE STRONGLY ENCOURAGED TO READ THIS BOOKLET AND CALL WITH ANY QUESTIONS PRIOR TO STARTING WORK.***

*This information is subject to revision.*

## **Before Beginning Any Work**

1. The KWD requires **at least one week's notice** before any work can begin. This allows the KWD time to review the project with the owner/contractor and schedule installations and inspections, etc. **The owner/contractor must contact the KWD at (207) 439-1128 prior to beginning work.**
2. Pursuant to Federal Law, the owner/contractor must contact Dig Safe at 811, or 1-888-344-7233 at least three (3) working days prior to the date work is scheduled to begin. A Dig Safe Project Number is required prior to excavation.
3. The owner/contractor shall not operate any hydrants, valves or curb stops that are the property of the KWD, without the expressed permission of the KWD.
4. The owner/contractor shall be responsible for notifying all users/property owners affected, prior to shutting off any services. Appropriate agencies shall also be notified.

# **Installation Requirements**

## **INSPECTION SERVICES:**

Installation inspections will be performed by the District or its representative and paid for by the Developer or Contractor. Full time inspections will be performed by the District or its representative at the jobbing hourly rate. Inspections will be performed during regular business hours 7:00 am – 3:00 pm, Monday – Friday, unless a prior request is issued and approved by the KWD.

## **BEDDING AND BACKFILL:**

- Ledge must be fully excavated a minimum of 12” below and 12” on either side of the pipe.
- A Minimum of 6” of clean sand bedding under the pipe and 12” on either side of the pipe is required.
- Pipe Bedding – AWWA C600 Pipe Laying Sec. 4 standards shall be followed for the installations of water mains and appurtenances. Trenches shall be flat bottomed, with 6” of compacted clean sand beneath and 12” above the pipe. Where ledge is encountered, 12” of compacted clean sand shall be installed beneath the pipe. The trench will be kept dewatered during pipe laying.  
The pipe bedding shall be clean granular sand, free from organic matter, frozen material or any other objectionable material and shall meet the following requirement: 100% passing a 2” sieve.
- Stone Dust is NOT an acceptable substitute for sand.
- A Minimum of 12” of compacted sand above the pipe is required. Compaction can be accomplished by either the excavator bucket or a mechanical compactor.
- The remainder of the trench is to have compacted backfill material pre-approved by the District or its representative. Compaction of this material must be by a mechanical compactor.
- Minimum earth cover over the top of the pipe is 5’-0” (top of pipe to finish grade).
- Locking Tyton / Fastite gaskets shall be installed in the last 3 sections of pipe that is assembled before installing the blow-off assembly.
- The Blow-Off assembly will require that an MJ Tap Cap be installed which will require a spigot end of the pipe. (additional details below).
- Field cutting of pipe is not allowed within 3 feet of the bell of the pipe, unless the nominal O.D. of the pipe is maintained.

## **BLOW-OFF INSTALLATION (SEE DETAIL SHEETS):**

- High density polyethylene (H.D.P.E.) blow-offs are fabricated by KWD (time and material rates apply), and installed by the contractor.
- Valve shall be 2” ball valve, Riser shall be 2” H.D.P.E. plastic pipe.
- Contractor is responsible for backfilling once the Blow-Off and thrust blocks are installed.
- Sand backfill is required from the base of the valve and riser pipe to the top of the ground.
- Care must be taken not to dig beyond the blow-off installation area, such that thrust blocks can be set against undisturbed soil.
- 26” top flange valve box top sections and covers are to be installed over all Blow-Off assemblies, over the service box and over the riser pipe.

### **SERVICES LINE INSTALLATIONS:**

- Upon completion of the water main, and a passing pressure test, installation of services may be proceed.
- On Ductile mains, 1” direct taps will be performed, to a 1” cc Corp, to 1” “K” Copper Service Line, to a 1” Ballvalve Curb stop. The Curb stop will have a 36” s.s. Service Rod and a 4.5’-5.5’ Service Box. A Bibby with Cover labeled “Water” will be installed over the Service Box.
- On HDPE mains, 1” Service Saddles will be installed prior to tapping the main. A 1” cc Corp, to 1” CTS plastic Service Line, to a 1” Ballvalve Curb stop. The Curb stop will have a 36” s.s. Service Rod and a 4.5’-5.5’ Service Box. Tracer wire will be installed to the CTS line. A 6” top flange valve box top section with Cover labeled “WATER” will be installed over the Service Box.
- Clean sand bedding is also required 6” below the copper tubing and 12” to the sides and above. Sand backfill is also required around the service box, from the foot piece to the cap.
- Services that reach or exceed 150 feet from the curb stop will require a meter vault to be installed.

### **TEST SERVICE / CHLORINATION TAP:**

The KWD or Contractor shall install a 1” corporation and a CTS plastic riser with a 1” curb stop cnpj x feip, on the first length of water main that is installed, as close to the mainline valve as is practical. Upon successful completion of a pressure test, chlorination and a negative bacteria test, the Contractor shall excavate to allow removal of the test service and installation of a brass plug by either KWD or the Contractor (time and material rates apply).

### **FIRE HYDRANT INSTALLATIONS:**

- The traffic break flange of the hydrant shall not be less than 2” above the finish grade, nor more than 6” above the finish grade.
- Sand backfill is required around the barrel of the hydrant, from the shoe to the ground’s surface.
- Valve anchoring tees are to be used for all hydrant installations and lateral water mains.
- Marker poles will be provided by the District and installed by the contractor in the appropriate location (material rates apply).

### **WATER MAIN ACCEPTANCE POLICY:**

- The newly installed water main will be filled, flushed, hydrostatically tested and chlorinated by the contractor.
- A negative bacteria result is needed before the water is used for any reason. The contractor or KWD will take this sample and have it analyzed.
- An as-built drawing of the water main installation performed by a licensed surveyor or engineer is required before acceptance of the main by KWD.
- Receipt of an electronic version of the project plan.
- Acknowledgement and execution of any agreements (fire protection lines, fire hydrants, etc.).
- Execution of an Easement to the KWD, for any mains installed in non-public right of ways. This includes both the drafting and recording of the Easement.
- Payment shall be made to KWD for all invoiced services and materials.

## **METERS:**

- Meters are both supplied and installed by KWD (time and material rates apply).
- A sketch is available from the District, outlining the required plumbing setup to receive the meter.
- Type “L” Copper should be used in the installation.

## **NOTES:**

- All materials that are installed are to be made in the USA or Canada, unless otherwise approved by the KWD.
- Material Submittal Sheets (Cut Sheets) shall be submitted to the KWD for approvable prior purchasing the materials.
- Inspection and service work performed by KWD will be billed at the District’s current time and material rates. Services provided by a third party will be billed at their rate.
- The horizontal distance between water and sewer lines shall be a minimum of 10 feet. Anytime a sewer line crosses above a water main, one full section of typical sewer pipe must be replaced with a full section of SDR-21 quality pipe. The full section of SDR-21 pipe shall be centered upon the crossing to maximize joint distance from the watermain and shall have a minimum clearance of 18” above the watermain.
- During new construction groundwork, the Owner / Contractor is responsible for protecting any service or meter that may be in danger of freezing. Associated damage repair costs will be the responsibility of the Owner / Contractor.
- The installation of H.D.P.E. main and CTS Plastic service lines will require the installation of Copper Head Brand tracing wire and Snake Bite Brand connectors. The KWD has very specific requirements for the installation of the tracer wire. The on-site inspector will provide detailed guidance at the time of installation.
- GPK Products, Inc. Schedule 40 x SDR-35 G “No Stop” adaptors must be used for all SDR-35 to SDR-21 connections. Connections of SDR-21 to other types of sewer pipe shall use solid couplings. Flexible couplings will NOT be permitted.

# **Water Line Construction Material Specifications**

## **WATER MAIN:**

- Ductile Iron
- Class 52 thickness
- Tyton / Fastite joint
- Double cement lined
- Zinc coated

## **ALTERNATE WATER MAIN MATERIAL:**

- High Density Polyethylene (H.D.P.E.)
- SDR 11
- Butt Fusion / Electrofusion Couplings
- Blue Stripe
- Copper Head Brand tracer wire is required on the main and all laterals

## **DUCTILE IRON FITTINGS:**

- Class 350
- Made in the USA or Canada

## **DUCTILE IRON GATE VALVES:**

- 250 P.S.I. working pressure
- Open left
- Resilient wedge
- Valves 16" or greater must be Horizontal with Bevel Gear
- Stainless steel nuts and bolts
- Stainless steel or bronze operating nut
- Valve centering rings are required
- Mud plugs are required

## **FIRE HYDRANTS:**

- AFC Waterous Pacer WB 67
- Clow Medallion
- Kennedy Valve Guardian K81-D
- Open left
- Non draining barrel

## **SERVICE BOXES:**

- 4 ½' - 5 ½' height, cap with rope thread and pentagon nut

**VALVE BOXES:**

- Cast iron
- 36” top flange
- 36” bottom base belled (minimum length)
- 5 ¼” diameter
- Drop in cover with pick hole with the word “WATER” cast in the cover
- Made in the USA or Canada

**CORPORATIONS:**

- Minimum size 1” for residential
- Mac Pac compression style nut
- Ball construction
- AY McDonald or Ford brand
- CC thread type

**CURB STOPS:**

- Minimum size 1” for residential
- Mac Pac compression style nut
- Ball construction
- AY McDonald or Ford brand

**SERVICE LINES:**

- Service lines shall be K-copper tubing
- Minimum size of tubing is 1”
- CTS Plastic tubing may be used only when installing an H.D.P.E. main
- ALL service boxes are to be protected using a 5 ¼” x 6” valve box top extension with the cover stamped “WATER”

**STAINLESS STEEL SERVICE RODS:**

- 5/8” x 36” long, with Brass Cotter Pins

**TAPPING SLEEVE:**

- Series 304 stainless steel
- Ductile iron or stainless steel welded flange
- Size on size taps are NOT permitted on cast iron water mains

**RETAINER GLANDS:**

- Romac grip ring brand (R-Blue T-Bolts and nuts required)
- MJ Field Lok brand (R-Blue T-Bolts and nuts required)
- MEGA Lug brand (R-Blue T-Bolts and nuts required)

**SERVICE SADDLES:**

- Ductile Iron body
- Nylon coated body
- Double stainless steel straps
- Electrofusion service saddles with cc threads are required when using H.D.P.E. pipe



**2" Female Poly Cam Fitting with Plug, Valve Box Top Section and Cover.**

**KWD to provide 2" SDR Riser Pipe, and the Contractor will provide all other fittings per KWD detail**

**2" SDR 11 HDPE Riser (provided by the KWD)**

**2" Male Poly Cam Fitting, 2" Elbow, 2" x 12" Nipple, 2" FE x FE ball valve curb stop, 2" x 6" Nipple, 36" stainless steel rod, service box, Valve Box Top Section and Cover.**

# **KITTERY WATER DISTRICT**

## **Standard 2 - Inch Blow Off Detail**

### **This is a parts list beginning at the tapped MJ Cap or Plug:**

- 2" x 6" Brass Nipple
- 2" FE x FE Ball Valve Curb Stop
- 2" x 12" Brass Nipple
- 2" Brass Elbow
- 2" Male Poly Cam \*
- 2" SDR11 H.D.P.E. Pipe \*
- 2" Female Poly Cam \*
- 2" Brass Plug

### **Also: After the assembly is installed:**

- Service Box Foot Piece
- Service Box (4' - 6" x 5' - 6")
- 36" x 5/8" Diameter Stainless Steel Service Rod
- Valve Box Cover (2)
- 26" Valve Box Top Section (2)

\* Riser Pipe is welded to the specified length by the Kittery Water District

## New Meter Installation – Residential

### New Meter Installation - Residential

\*KWD will provide meter spud, meter, and dual check valve.  
Meter sizes: 5/8", 3/4", 1" (Determined by water usage)

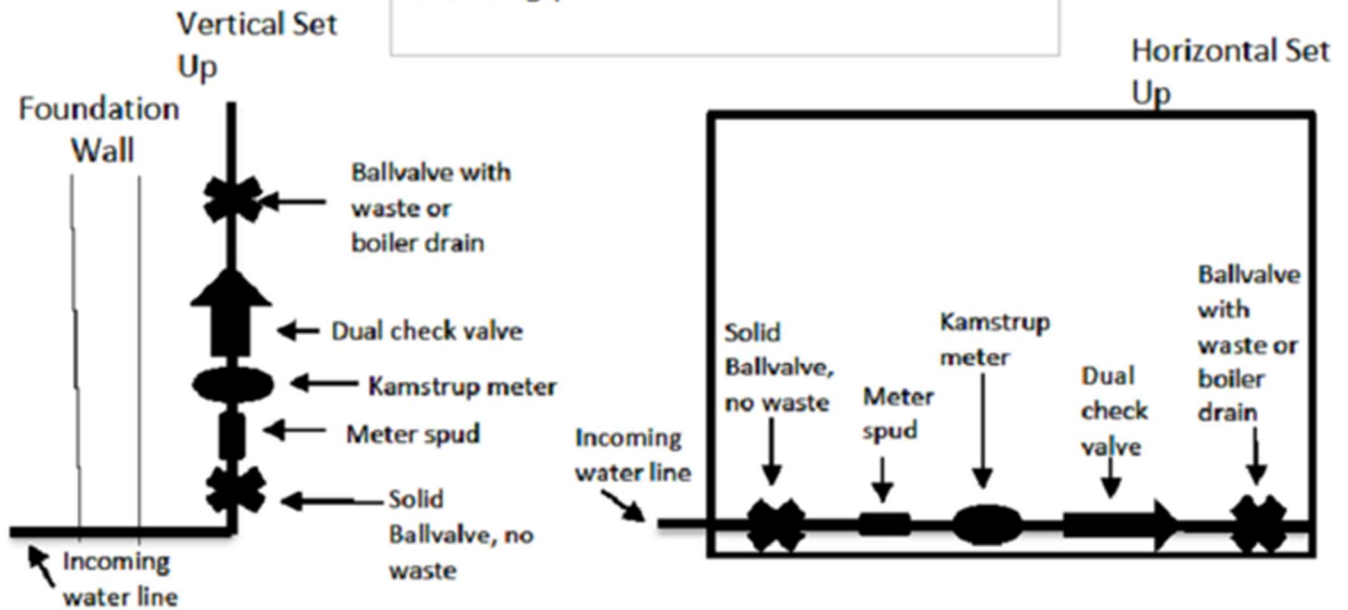

## New Meter Installation – Commercial

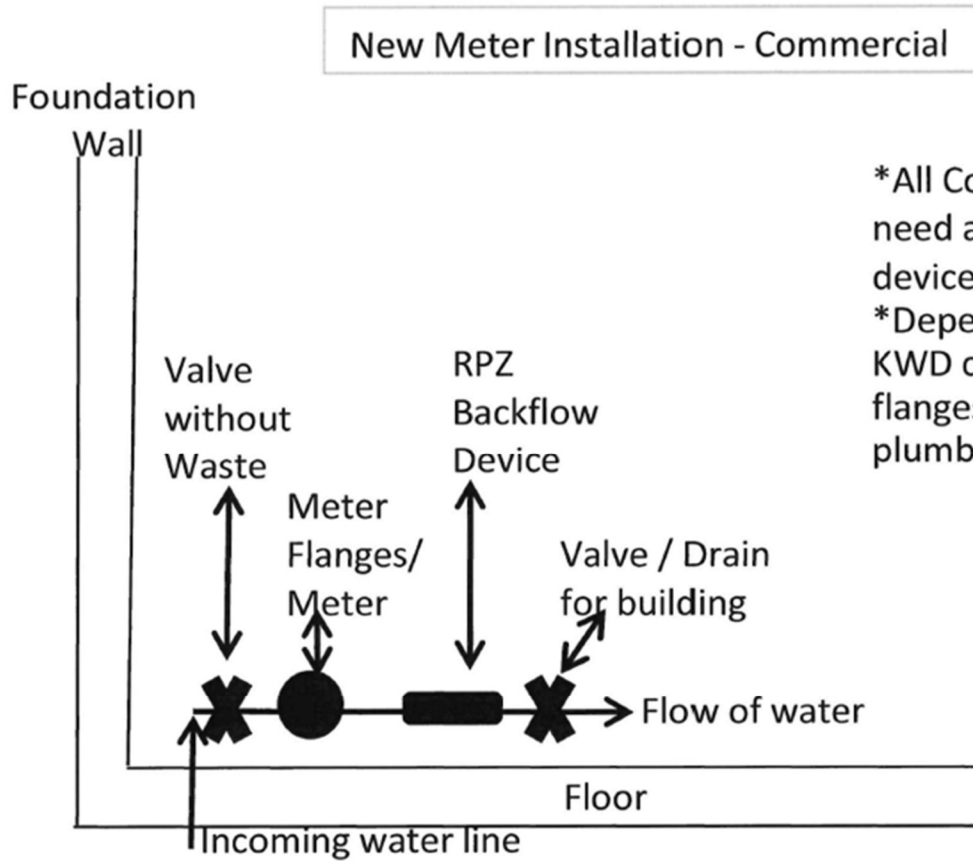

\*All Commercial properties need a testable RPZ backflow device.

\*Depending on size of meter, KWD can provide different flanges or tail pieces for the plumber.

## New Meter Installation – Eliot Deduct

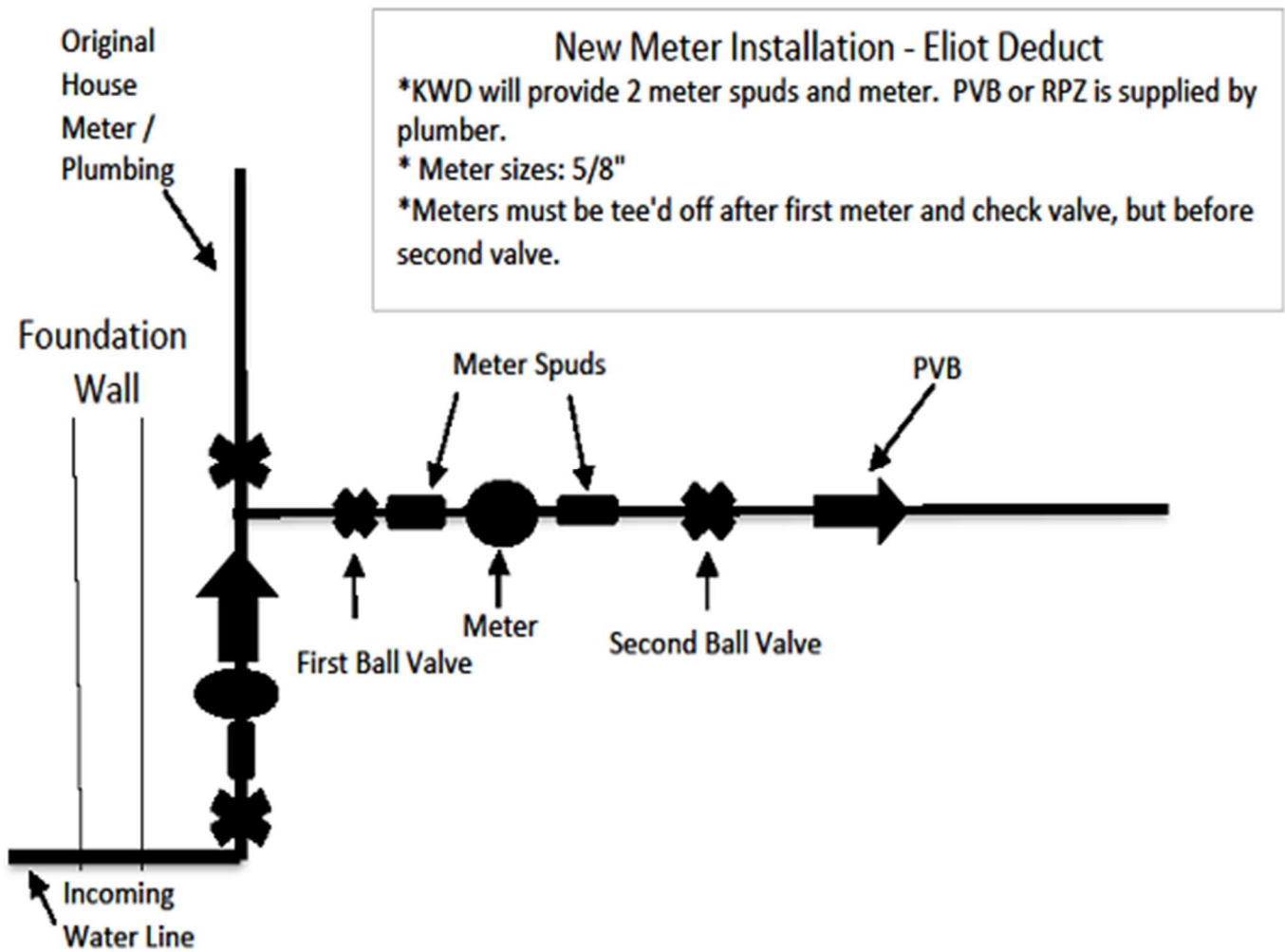

# New Meter Installation - Kittery Second Irrigation

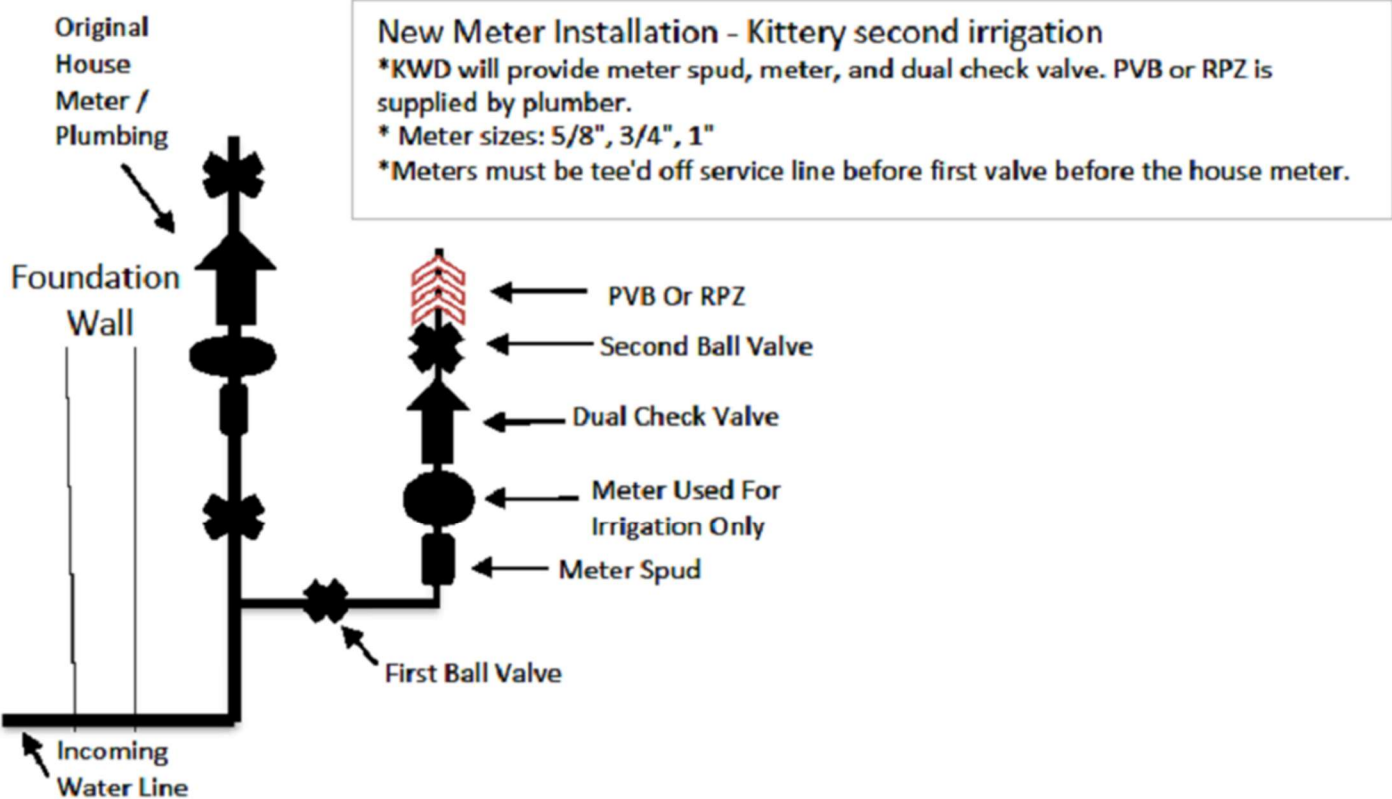

# KITTERY WATER DISTRICT

## WATER LINE CONSTRUCTION SPECIFICATIONS

APRIL 2026



If you have any questions, please call the office at (207) 439-1128 or email at [info@kitterywater.org](mailto:info@kitterywater.org). Your inquiry will be directed to the appropriate staff member, who will follow up as quickly as is possible.

# Table of Contents

Introduction .....	3
Before Beginning Any Work .....	4
Installation Requirements.....	5
Water Line Construction Material Specifications.....	8
Standard 2 - Inch Blow Off Detail .....	11
New Meter Installation – Residential.....	12
New Meter Installation – Commercial.....	13
New Meter Installation – Eliot Deduct .....	14
New Meter Installation- Kittery Second Irrigation.....	15

## **Introduction**

This information is intended to inform and guide homeowners and contractors regarding procedures to follow while working on Kittery Water District (here after KWD) water lines. **This summary does not relieve the owner/contractor of the responsibility for meeting all State and Federal requirements pertaining to the installation of water and sewer lines.**

NOTE: Provided that both the material specifications and installation requirements of the KWD are followed, upon successful installation and testing of the underground and aboveground infrastructure, KWD will accept the ownership of the infrastructure for perpetuity. If the infrastructure is NOT located within the Town or State right-of-way, a Utility Easement will need to be issued to the KWD.

***NOTE: ALL PARTIES ARE STRONGLY ENCOURAGED TO READ THIS BOOKLET AND CALL WITH ANY QUESTIONS PRIOR TO STARTING WORK.***

*This information is subject to revision.*

## **Before Beginning Any Work**

1. The KWD requires **at least one week's notice** before any work can begin. This allows the KWD time to review the project with the owner/contractor and schedule installations and inspections, etc. **The owner/contractor must contact the KWD at (207) 439-1128 prior to beginning work.**
2. Pursuant to Federal Law, the owner/contractor must contact Dig Safe at 811, or 1-888-344-7233 at least three (3) working days prior to the date work is scheduled to begin. A Dig Safe Project Number is required prior to excavation.
3. The owner/contractor shall not operate any hydrants, valves or curb stops that are the property of the KWD, without the expressed permission of the KWD.
4. The owner/contractor shall be responsible for notifying all users/property owners affected, prior to shutting off any services. Appropriate agencies shall also be notified.

# **Installation Requirements**

## **INSPECTION SERVICES:**

Installation inspections will be performed by the District or its representative and paid for by the Developer or Contractor. Full time inspections will be performed by the District or its representative at the jobbing hourly rate. Inspections will be performed during regular business hours 7:00 am – 3:00 pm, Monday – Friday, unless a prior request is issued and approved by the KWD.

## **BEDDING AND BACKFILL:**

- Ledge must be fully excavated a minimum of 12” below and 12” on either side of the pipe.
- A Minimum of 6” of clean sand bedding under the pipe and 12” on either side of the pipe is required.
- Pipe Bedding – AWWA C600 Pipe Laying Sec. 4 standards shall be followed for the installations of water mains and appurtenances. Trenches shall be flat bottomed, with 6” of compacted clean sand beneath and 12” above the pipe. Where ledge is encountered, 12” of compacted clean sand shall be installed beneath the pipe. The trench will be kept dewatered during pipe laying.  
The pipe bedding shall be clean granular sand, free from organic matter, frozen material or any other objectionable material and shall meet the following requirement: 100% passing a 2” sieve.
- Stone Dust is NOT an acceptable substitute for sand.
- A Minimum of 12” of compacted sand above the pipe is required. Compaction can be accomplished by either the excavator bucket or a mechanical compactor.
- The remainder of the trench is to have compacted backfill material pre-approved by the District or its representative. Compaction of this material must be by a mechanical compactor.
- Minimum earth cover over the top of the pipe is 5’-0” (top of pipe to finish grade).
- Locking Tyton / Fastite gaskets shall be installed in the last 3 sections of pipe that is assembled before installing the blow-off assembly.
- The Blow-Off assembly will require that an MJ Tap Cap be installed which will require a spigot end of the pipe. (additional details below).
- Field cutting of pipe is not allowed within 3 feet of the bell of the pipe, unless the nominal O.D. of the pipe is maintained.

## **BLOW-OFF INSTALLATION (SEE DETAIL SHEETS):**

- High density polyethylene (H.D.P.E.) blow-offs are fabricated by KWD (time and material rates apply), and installed by the contractor.
- Valve shall be 2” ball valve, Riser shall be 2” H.D.P.E. plastic pipe.
- Contractor is responsible for backfilling once the Blow-Off and thrust blocks are installed.
- Sand backfill is required from the base of the valve and riser pipe to the top of the ground.
- Care must be taken not to dig beyond the blow-off installation area, such that thrust blocks can be set against undisturbed soil.
- 26” top flange valve box top sections and covers are to be installed over all Blow-Off assemblies, over the service box and over the riser pipe.

### **SERVICES LINE INSTALLATIONS:**

- Upon completion of the water main, and a passing pressure test, installation of services may be proceed.
- On Ductile mains, 1” direct taps will be performed, to a 1” cc Corp, to 1” “K” Copper Service Line, to a 1” Ballvalve Curb stop. The Curb stop will have a 36” s.s. Service Rod and a 4.5’-5.5’ Service Box. A Bibby with Cover labeled “Water” will be installed over the Service Box.
- On HDPE mains, 1” Service Saddles will be installed prior to tapping the main. A 1” cc Corp, to 1” CTS plastic Service Line, to a 1” Ballvalve Curb stop. The Curb stop will have a 36” s.s. Service Rod and a 4.5’-5.5’ Service Box. Tracer wire will be installed to the CTS line. A 6” top flange valve box top section with Cover labeled “WATER” will be installed over the Service Box.
- Clean sand bedding is also required 6” below the copper tubing and 12” to the sides and above. Sand backfill is also required around the service box, from the foot piece to the cap.
- Services that reach or exceed 150 feet from the curb stop will require a meter vault to be installed.

### **TEST SERVICE / CHLORINATION TAP:**

The KWD or Contractor shall install a 1” corporation and a CTS plastic riser with a 1” curb stop cnpj x feip, on the first length of water main that is installed, as close to the mainline valve as is practical. Upon successful completion of a pressure test, chlorination and a negative bacteria test, the Contractor shall excavate to allow removal of the test service and installation of a brass plug by either KWD or the Contractor (time and material rates apply).

### **FIRE HYDRANT INSTALLATIONS:**

- The traffic break flange of the hydrant shall not be less than 2” above the finish grade, nor more than 6” above the finish grade.
- Sand backfill is required around the barrel of the hydrant, from the shoe to the ground’s surface.
- Valve anchoring tees are to be used for all hydrant installations and lateral water mains.
- Marker poles will be provided by the District and installed by the contractor in the appropriate location (material rates apply).

### **WATER MAIN ACCEPTANCE POLICY:**

- The newly installed water main will be filled, flushed, hydrostatically tested and chlorinated by the contractor.
- A negative bacteria result is needed before the water is used for any reason. The contractor or KWD will take this sample and have it analyzed.
- An as-built drawing of the water main installation performed by a licensed surveyor or engineer is required before acceptance of the main by KWD.
- Receipt of an electronic version of the project plan.
- Acknowledgement and execution of any agreements (fire protection lines, fire hydrants, etc.).
- Execution of an Easement to the KWD, for any mains installed in non-public right of ways. This includes both the drafting and recording of the Easement.
- Payment shall be made to KWD for all invoiced services and materials.

## **METERS:**

- Meters are both supplied and installed by KWD (time and material rates apply).
- A sketch is available from the District, outlining the required plumbing setup to receive the meter.
- Type “L” Copper should be used in the installation.

## **NOTES:**

- All materials that are installed are to be made in the USA or Canada, unless otherwise approved by the KWD.
- Material Submittal Sheets (Cut Sheets) shall be submitted to the KWD for approvable prior purchasing the materials.
- Inspection and service work performed by KWD will be billed at the District’s current time and material rates. Services provided by a third party will be billed at their rate.
- The horizontal distance between water and sewer lines shall be a minimum of 10 feet. Anytime a sewer line crosses above a water main, one full section of typical sewer pipe must be replaced with a full section of SDR-21 quality pipe. The full section of SDR-21 pipe shall be centered upon the crossing to maximize joint distance from the watermain and shall have a minimum clearance of 18” above the watermain.
- During new construction groundwork, the Owner / Contractor is responsible for protecting any service or meter that may be in danger of freezing. Associated damage repair costs will be the responsibility of the Owner / Contractor.
- The installation of H.D.P.E. main and CTS Plastic service lines will require the installation of Copper Head Brand tracing wire and Snake Bite Brand connectors. The KWD has very specific requirements for the installation of the tracer wire. The on-site inspector will provide detailed guidance at the time of installation.
- GPK Products, Inc. Schedule 40 x SDR-35 G “No Stop” adaptors must be used for all SDR-35 to SDR-21 connections. Connections of SDR-21 to other types of sewer pipe shall use solid couplings. Flexible couplings will NOT be permitted.

# **Water Line Construction Material Specifications**

## **WATER MAIN:**

- Ductile Iron
- Class 52 thickness
- Tyton / Fastite joint
- Double cement lined
- Zinc coated

## **ALTERNATE WATER MAIN MATERIAL:**

- High Density Polyethylene (H.D.P.E.)
- SDR 11
- Butt Fusion / Electrofusion Couplings
- Blue Stripe
- Copper Head Brand tracer wire is required on the main and all laterals

## **DUCTILE IRON FITTINGS:**

- Class 350
- Made in the USA or Canada

## **DUCTILE IRON GATE VALVES:**

- 250 P.S.I. working pressure
- Open left
- Resilient wedge
- Valves 16" or greater must be Horizontal with Bevel Gear
- Stainless steel nuts and bolts
- Stainless steel or bronze operating nut
- Valve centering rings are required
- Mud plugs are required

## **FIRE HYDRANTS:**

- AFC Waterous Pacer WB 67
- Clow Medallion
- Kennedy Valve Guardian K81-D
- Open left
- Non draining barrel

## **SERVICE BOXES:**

- 4 ½' - 5 ½' height, cap with rope thread and pentagon nut

**VALVE BOXES:**

- Cast iron
- 36” top flange
- 36” bottom base belled (minimum length)
- 5 ¼” diameter
- Drop in cover with pick hole with the word “WATER” cast in the cover
- Made in the USA or Canada

**CORPORATIONS:**

- Minimum size 1” for residential
- Mac Pac compression style nut
- Ball construction
- AY McDonald or Ford brand
- CC thread type

**CURB STOPS:**

- Minimum size 1” for residential
- Mac Pac compression style nut
- Ball construction
- AY McDonald or Ford brand

**SERVICE LINES:**

- Service lines shall be K-copper tubing
- Minimum size of tubing is 1”
- CTS Plastic tubing may be used only when installing an H.D.P.E. main
- ALL service boxes are to be protected using a 5 ¼” x 6” valve box top extension with the cover stamped “WATER”

**STAINLESS STEEL SERVICE RODS:**

- 5/8” x 36” long, with Brass Cotter Pins

**TAPPING SLEEVE:**

- Series 304 stainless steel
- Ductile iron or stainless steel welded flange
- Size on size taps are NOT permitted on cast iron water mains

**RETAINER GLANDS:**

- Romac grip ring brand (R-Blue T-Bolts and nuts required)
- MJ Field Lok brand (R-Blue T-Bolts and nuts required)
- MEGA Lug brand (R-Blue T-Bolts and nuts required)

**SERVICE SADDLES:**

- Ductile Iron body
- Nylon coated body
- Double stainless steel straps
- Electrofusion service saddles with cc threads are required when using H.D.P.E. pipe



**2" Female Poly Cam Fitting with Plug, Valve Box Top Section and Cover.**

**KWD to provide 2" SDR Riser Pipe, and the Contractor will provide all other fittings per KWD detail**

**2" SDR 11 HDPE Riser (provided by the KWD)**

**2" Male Poly Cam Fitting, 2" Elbow, 2" x 12" Nipple, 2" FE x FE ball valve curb stop, 2" x 6" Nipple, 36" stainless steel rod, service box, Valve Box Top Section and Cover.**

**KITTERY WATER DISTRICT**  
**Standard 2 - Inch Blow Off Detail**

**This is a parts list beginning at the tapped MJ Cap or Plug:**

- 2" x 6" Brass Nipple
- 2" FE x FE Ball Valve Curb Stop
- 2" x 12" Brass Nipple
- 2" Brass Elbow
- 2" Male Poly Cam \*
- 2" SDR11 H.D.P.E. Pipe \*
- 2" Female Poly Cam \*
- 2" Brass Plug

**Also: After the assembly is installed:**

- Service Box Foot Piece
- Service Box (4' - 6" x 5' - 6")
- 36" x 5/8" Diameter Stainless Steel Service Rod
- Valve Box Cover (2)
- 26" Valve Box Top Section (2)

\* Riser Pipe is welded to the specified length by the Kittery Water District

## New Meter Installation – Residential

### New Meter Installation - Residential

\*KWD will provide meter spud, meter, and dual check valve.  
Meter sizes: 5/8", 3/4", 1" (Determined by water usage)

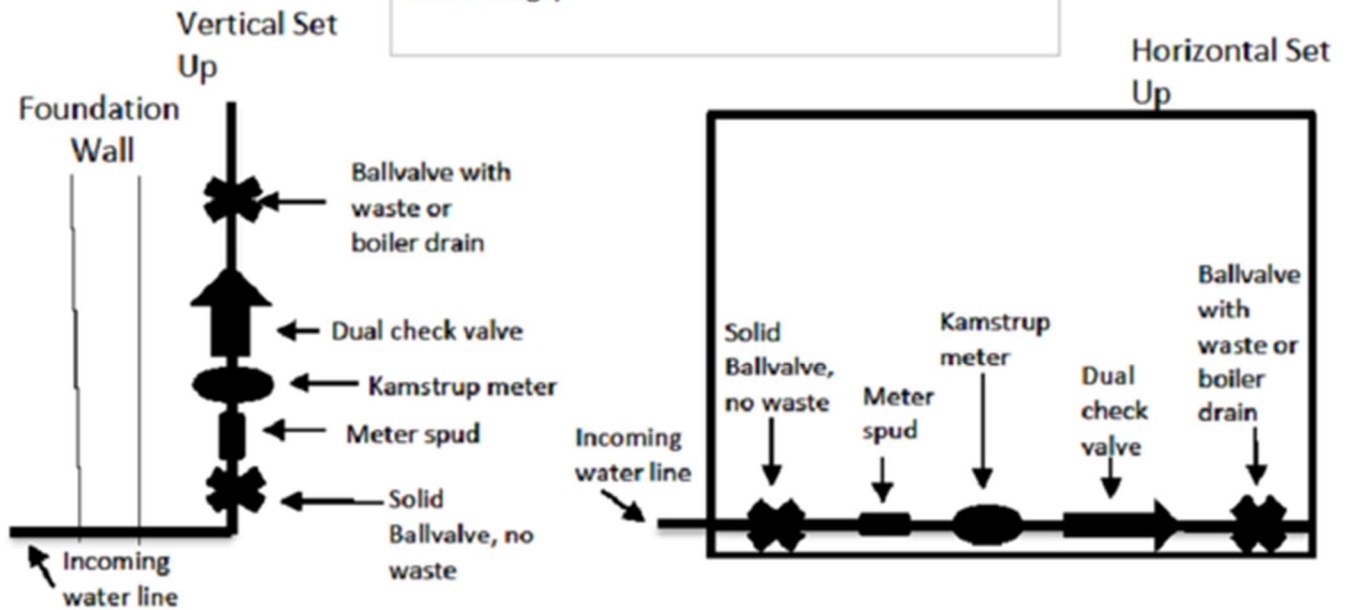

## New Meter Installation – Commercial

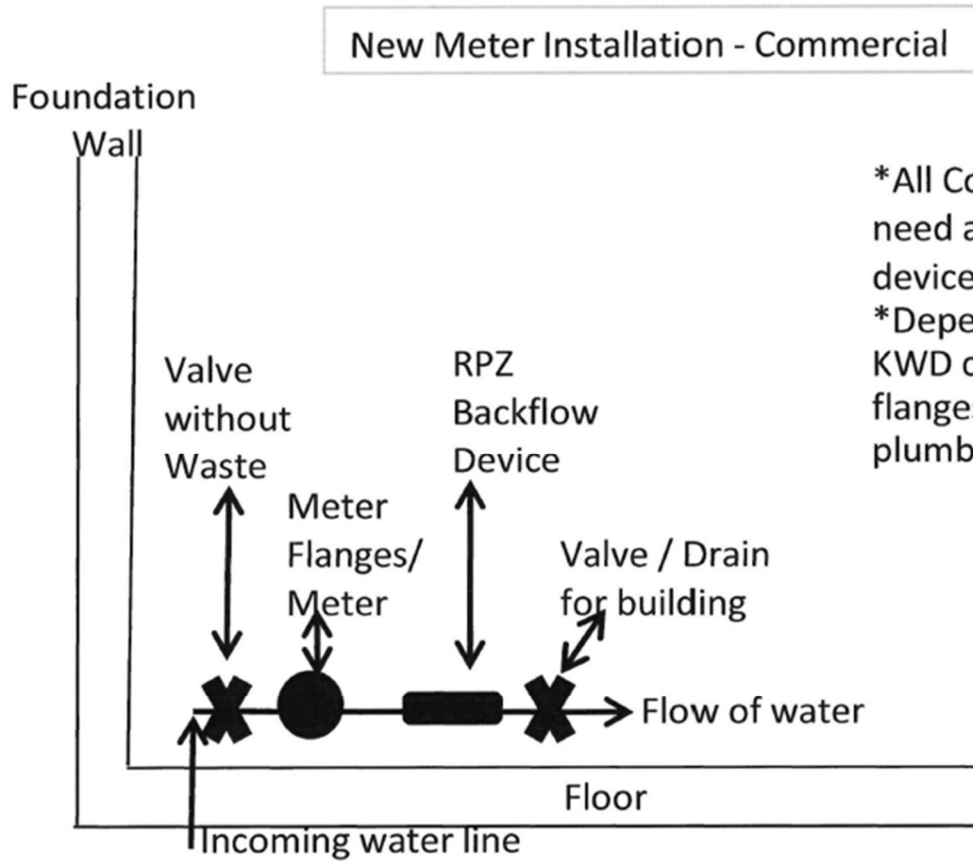

\*All Commercial properties need a testable RPZ backflow device.

\*Depending on size of meter, KWD can provide different flanges or tail pieces for the plumber.

## New Meter Installation – Eliot Deduct

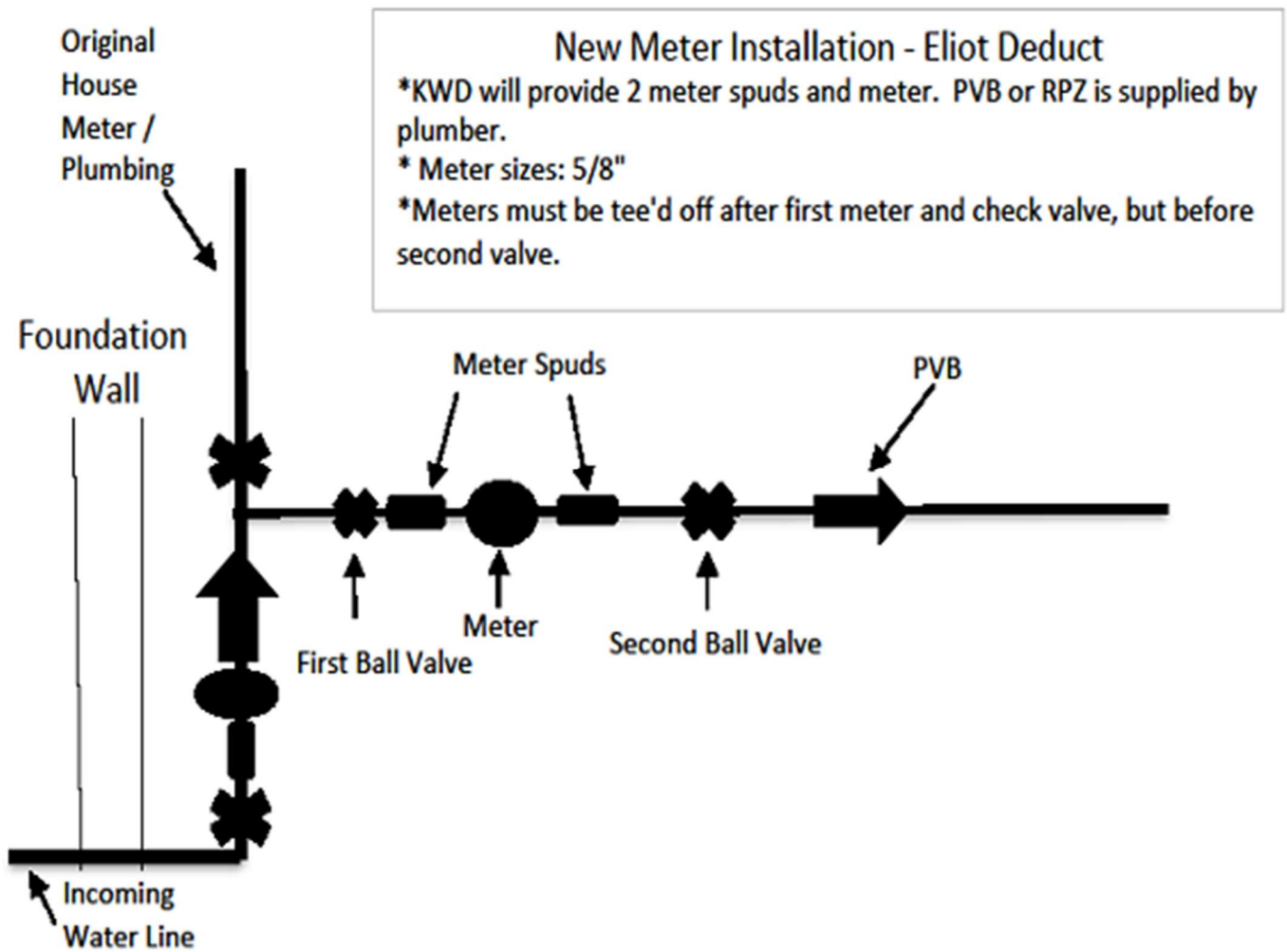

# New Meter Installation - Kittery Second Irrigation

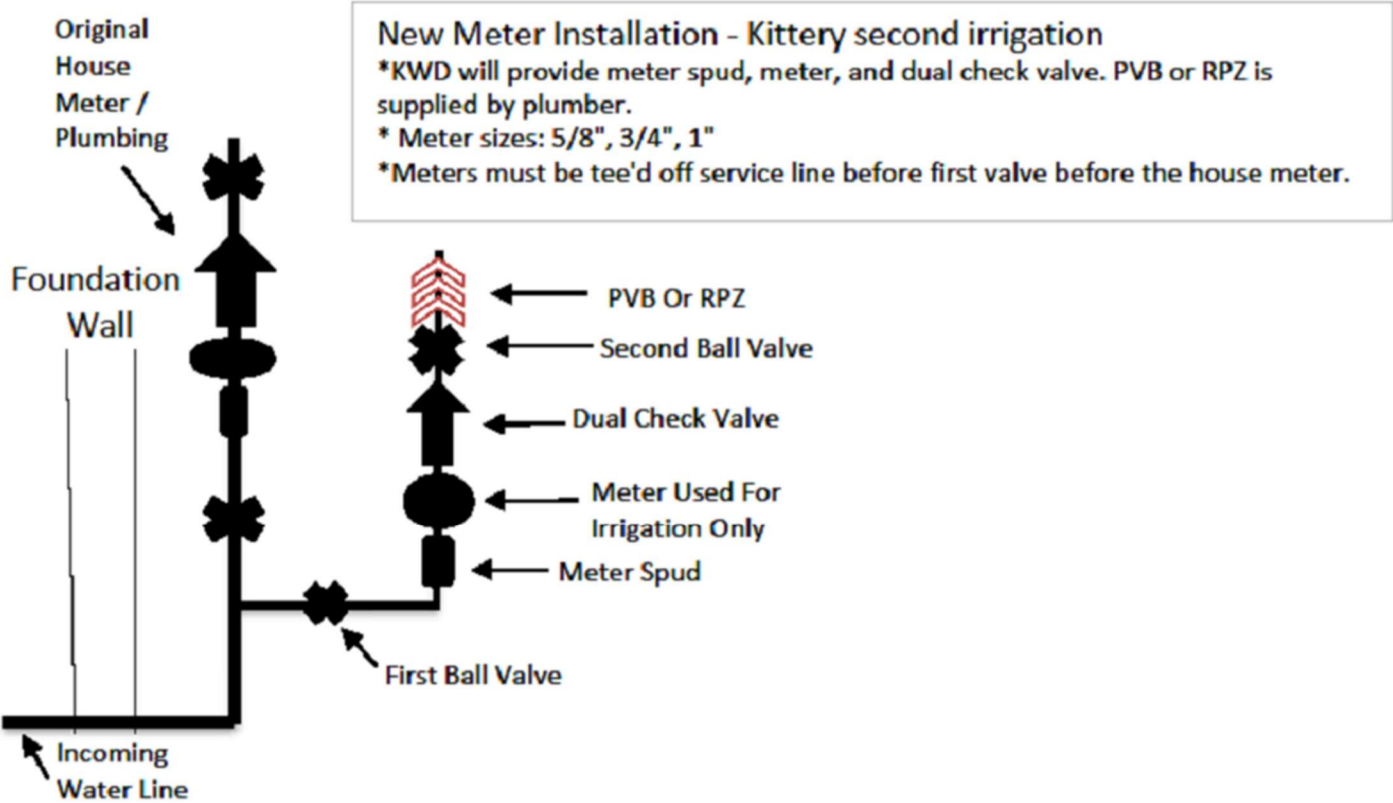

# KITTERY WATER DISTRICT

## WATER LINE CONSTRUCTION SPECIFICATIONS

APRIL 2026

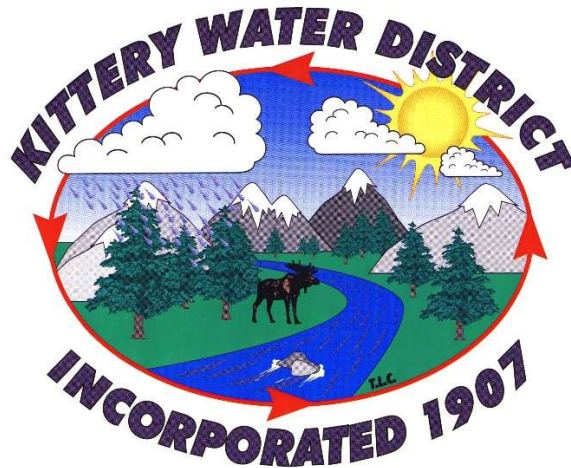

If you have any questions, please call the office at (207) 439-1128 or email at [info@kitterywater.org](mailto:info@kitterywater.org). Your inquiry will be directed to the appropriate staff member, who will follow up as quickly as is possible.

# Table of Contents

Introduction .....	3
Before Beginning Any Work .....	4
Installation Requirements.....	5
Water Line Construction Material Specifications.....	8
Standard 2 - Inch Blow Off Detail .....	11
New Meter Installation – Residential.....	12
New Meter Installation – Commercial.....	13
New Meter Installation – Eliot Deduct .....	14
New Meter Installation- Kittery Second Irrigation.....	15

## **Introduction**

This information is intended to inform and guide homeowners and contractors regarding procedures to follow while working on Kittery Water District (here after KWD) water lines. **This summary does not relieve the owner/contractor of the responsibility for meeting all State and Federal requirements pertaining to the installation of water and sewer lines.**

NOTE: Provided that both the material specifications and installation requirements of the KWD are followed, upon successful installation and testing of the underground and aboveground infrastructure, KWD will accept the ownership of the infrastructure for perpetuity. If the infrastructure is NOT located within the Town or State right-of-way, a Utility Easement will need to be issued to the KWD.

***NOTE: ALL PARTIES ARE STRONGLY ENCOURAGED TO READ THIS BOOKLET AND CALL WITH ANY QUESTIONS PRIOR TO STARTING WORK.***

*This information is subject to revision.*

## **Before Beginning Any Work**

1. The KWD requires **at least one week's notice** before any work can begin. This allows the KWD time to review the project with the owner/contractor and schedule installations and inspections, etc. **The owner/contractor must contact the KWD at (207) 439-1128 prior to beginning work.**
2. Pursuant to Federal Law, the owner/contractor must contact Dig Safe at 811, or 1-888-344-7233 at least three (3) working days prior to the date work is scheduled to begin. A Dig Safe Project Number is required prior to excavation.
3. The owner/contractor shall not operate any hydrants, valves or curb stops that are the property of the KWD, without the expressed permission of the KWD.
4. The owner/contractor shall be responsible for notifying all users/property owners affected, prior to shutting off any services. Appropriate agencies shall also be notified.

# **Installation Requirements**

## **INSPECTION SERVICES:**

Installation inspections will be performed by the District or its representative and paid for by the Developer or Contractor. Full time inspections will be performed by the District or its representative at the jobbing hourly rate. Inspections will be performed during regular business hours 7:00 am – 3:00 pm, Monday – Friday, unless a prior request is issued and approved by the KWD.

## **BEDDING AND BACKFILL:**

- Ledge must be fully excavated a minimum of 12” below and 12” on either side of the pipe.
- A Minimum of 6” of clean sand bedding under the pipe and 12” on either side of the pipe is required.
- Pipe Bedding – AWWA C600 Pipe Laying Sec. 4 standards shall be followed for the installations of water mains and appurtenances. Trenches shall be flat bottomed, with 6” of compacted clean sand beneath and 12” above the pipe. Where ledge is encountered, 12” of compacted clean sand shall be installed beneath the pipe. The trench will be kept dewatered during pipe laying.  
The pipe bedding shall be clean granular sand, free from organic matter, frozen material or any other objectionable material and shall meet the following requirement: 100% passing a 2” sieve.
- Stone Dust is NOT an acceptable substitute for sand.
- A Minimum of 12” of compacted sand above the pipe is required. Compaction can be accomplished by either the excavator bucket or a mechanical compactor.
- The remainder of the trench is to have compacted backfill material pre-approved by the District or its representative. Compaction of this material must be by a mechanical compactor.
- Minimum earth cover over the top of the pipe is 5’-0” (top of pipe to finish grade).
- Locking Tyton / Fastite gaskets shall be installed in the last 3 sections of pipe that is assembled before installing the blow-off assembly.
- The Blow-Off assembly will require that an MJ Tap Cap be installed which will require a spigot end of the pipe. (additional details below).
- Field cutting of pipe is not allowed within 3 feet of the bell of the pipe, unless the nominal O.D. of the pipe is maintained.

## **BLOW-OFF INSTALLATION (SEE DETAIL SHEETS):**

- High density polyethylene (H.D.P.E.) blow-offs are fabricated by KWD (time and material rates apply), and installed by the contractor.
- Valve shall be 2” ball valve, Riser shall be 2” H.D.P.E. plastic pipe.
- Contractor is responsible for backfilling once the Blow-Off and thrust blocks are installed.
- Sand backfill is required from the base of the valve and riser pipe to the top of the ground.
- Care must be taken not to dig beyond the blow-off installation area, such that thrust blocks can be set against undisturbed soil.
- 26” top flange valve box top sections and covers are to be installed over all Blow-Off assemblies, over the service box and over the riser pipe.

### **SERVICES LINE INSTALLATIONS:**

- Upon completion of the water main, and a passing pressure test, installation of services may be proceed.
- On Ductile mains, 1” direct taps will be performed, to a 1” cc Corp, to 1” “K” Copper Service Line, to a 1” Ballvalve Curb stop. The Curb stop will have a 36” s.s. Service Rod and a 4.5’-5.5’ Service Box. A Bibby with Cover labeled “Water” will be installed over the Service Box.
- On HDPE mains, 1” Service Saddles will be installed prior to tapping the main. A 1” cc Corp, to 1” CTS plastic Service Line, to a 1” Ballvalve Curb stop. The Curb stop will have a 36” s.s. Service Rod and a 4.5’-5.5’ Service Box. Tracer wire will be installed to the CTS line. A 6” top flange valve box top section with Cover labeled “WATER” will be installed over the Service Box.
- Clean sand bedding is also required 6” below the copper tubing and 12” to the sides and above. Sand backfill is also required around the service box, from the foot piece to the cap.
- Services that reach or exceed 150 feet from the curb stop will require a meter vault to be installed.

### **TEST SERVICE / CHLORINATION TAP:**

The KWD or Contractor shall install a 1” corporation and a CTS plastic riser with a 1” curb stop cnpj x feip, on the first length of water main that is installed, as close to the mainline valve as is practical. Upon successful completion of a pressure test, chlorination and a negative bacteria test, the Contractor shall excavate to allow removal of the test service and installation of a brass plug by either KWD or the Contractor (time and material rates apply).

### **FIRE HYDRANT INSTALLATIONS:**

- The traffic break flange of the hydrant shall not be less than 2” above the finish grade, nor more than 6” above the finish grade.
- Sand backfill is required around the barrel of the hydrant, from the shoe to the ground’s surface.
- Valve anchoring tees are to be used for all hydrant installations and lateral water mains.
- Marker poles will be provided by the District and installed by the contractor in the appropriate location (material rates apply).

### **WATER MAIN ACCEPTANCE POLICY:**

- The newly installed water main will be filled, flushed, hydrostatically tested and chlorinated by the contractor.
- A negative bacteria result is needed before the water is used for any reason. The contractor or KWD will take this sample and have it analyzed.
- An as-built drawing of the water main installation performed by a licensed surveyor or engineer is required before acceptance of the main by KWD.
- Receipt of an electronic version of the project plan.
- Acknowledgement and execution of any agreements (fire protection lines, fire hydrants, etc.).
- Execution of an Easement to the KWD, for any mains installed in non-public right of ways. This includes both the drafting and recording of the Easement.
- Payment shall be made to KWD for all invoiced services and materials.

## **METERS:**

- Meters are both supplied and installed by KWD (time and material rates apply).
- A sketch is available from the District, outlining the required plumbing setup to receive the meter.
- Type “L” Copper should be used in the installation.

## **NOTES:**

- All materials that are installed are to be made in the USA or Canada, unless otherwise approved by the KWD.
- Material Submittal Sheets (Cut Sheets) shall be submitted to the KWD for approvable prior purchasing the materials.
- Inspection and service work performed by KWD will be billed at the District’s current time and material rates. Services provided by a third party will be billed at their rate.
- The horizontal distance between water and sewer lines shall be a minimum of 10 feet. Anytime a sewer line crosses above a water main, one full section of typical sewer pipe must be replaced with a full section of SDR-21 quality pipe. The full section of SDR-21 pipe shall be centered upon the crossing to maximize joint distance from the watermain and shall have a minimum clearance of 18” above the watermain.
- During new construction groundwork, the Owner / Contractor is responsible for protecting any service or meter that may be in danger of freezing. Associated damage repair costs will be the responsibility of the Owner / Contractor.
- The installation of H.D.P.E. main and CTS Plastic service lines will require the installation of Copper Head Brand tracing wire and Snake Bite Brand connectors. The KWD has very specific requirements for the installation of the tracer wire. The on-site inspector will provide detailed guidance at the time of installation.
- GPK Products, Inc. Schedule 40 x SDR-35 G “No Stop” adaptors must be used for all SDR-35 to SDR-21 connections. Connections of SDR-21 to other types of sewer pipe shall use solid couplings. Flexible couplings will NOT be permitted.

# **Water Line Construction Material Specifications**

## **WATER MAIN:**

- Ductile Iron
- Class 52 thickness
- Tyton / Fastite joint
- Double cement lined
- Zinc coated

## **ALTERNATE WATER MAIN MATERIAL:**

- High Density Polyethylene (H.D.P.E.)
- SDR 11
- Butt Fusion / Electrofusion Couplings
- Blue Stripe
- Copper Head Brand tracer wire is required on the main and all laterals

## **DUCTILE IRON FITTINGS:**

- Class 350
- Made in the USA or Canada

## **DUCTILE IRON GATE VALVES:**

- 250 P.S.I. working pressure
- Open left
- Resilient wedge
- Valves 16" or greater must be Horizontal with Bevel Gear
- Stainless steel nuts and bolts
- Stainless steel or bronze operating nut
- Valve centering rings are required
- Mud plugs are required

## **FIRE HYDRANTS:**

- AFC Waterous Pacer WB 67
- Clow Medallion
- Kennedy Valve Guardian K81-D
- Open left
- Non draining barrel

## **SERVICE BOXES:**

- 4 ½' - 5 ½' height, cap with rope thread and pentagon nut

**VALVE BOXES:**

- Cast iron
- 36” top flange
- 36” bottom base belled (minimum length)
- 5 ¼” diameter
- Drop in cover with pick hole with the word “WATER” cast in the cover
- Made in the USA or Canada

**CORPORATIONS:**

- Minimum size 1” for residential
- Mac Pac compression style nut
- Ball construction
- AY McDonald or Ford brand
- CC thread type

**CURB STOPS:**

- Minimum size 1” for residential
- Mac Pac compression style nut
- Ball construction
- AY McDonald or Ford brand

**SERVICE LINES:**

- Service lines shall be K-copper tubing
- Minimum size of tubing is 1”
- CTS Plastic tubing may be used only when installing an H.D.P.E. main
- ALL service boxes are to be protected using a 5 ¼” x 6” valve box top extension with the cover stamped “WATER”

**STAINLESS STEEL SERVICE RODS:**

- 5/8” x 36” long, with Brass Cotter Pins

**TAPPING SLEEVE:**

- Series 304 stainless steel
- Ductile iron or stainless steel welded flange
- Size on size taps are NOT permitted on cast iron water mains

**RETAINER GLANDS:**

- Romac grip ring brand (R-Blue T-Bolts and nuts required)
- MJ Field Lok brand (R-Blue T-Bolts and nuts required)
- MEGA Lug brand (R-Blue T-Bolts and nuts required)

**SERVICE SADDLES:**

- Ductile Iron body
- Nylon coated body
- Double stainless steel straps
- Electrofusion service saddles with cc threads are required when using H.D.P.E. pipe



**2" Female Poly  
Cam Fitting with  
Plug, Valve Box  
Top Section and  
Cover.**

**KWD to provide 2" SDR  
Riser Pipe, and the  
Contractor will provide  
all other fittings per  
KWD detail**

**2" SDR 11 HDPE  
Riser (provided  
by the KWD)**

**2" Male Poly Cam  
Fitting, 2" Elbow, 2"  
x 12" Nipple, 2" FE x  
FE ball valve curb  
stop, 2" x 6" Nipple,  
36" stainless steel  
rod, service box,  
Valve Box Top  
Section and Cover.**

**KITTERY WATER DISTRICT**  
**Standard 2 - Inch Blow Off Detail**

**This is a parts list beginning at the tapped MJ Cap or Plug:**

- 2" x 6" Brass Nipple
- 2" FE x FE Ball Valve Curb Stop
- 2" x 12" Brass Nipple
- 2" Brass Elbow
- 2" Male Poly Cam \*
- 2" SDR11 H.D.P.E. Pipe \*
- 2" Female Poly Cam \*
- 2" Brass Plug

**Also: After the assembly is installed:**

- Service Box Foot Piece
- Service Box (4' - 6" x 5' - 6")
- 36" x 5/8" Diameter Stainless Steel Service Rod
- Valve Box Cover (2)
- 26" Valve Box Top Section (2)

\* Riser Pipe is welded to the specified length by the Kittery Water District

## New Meter Installation – Residential

### New Meter Installation - Residential

\*KWD will provide meter spud, meter, and dual check valve.  
Meter sizes: 5/8", 3/4", 1" (Determined by water usage)

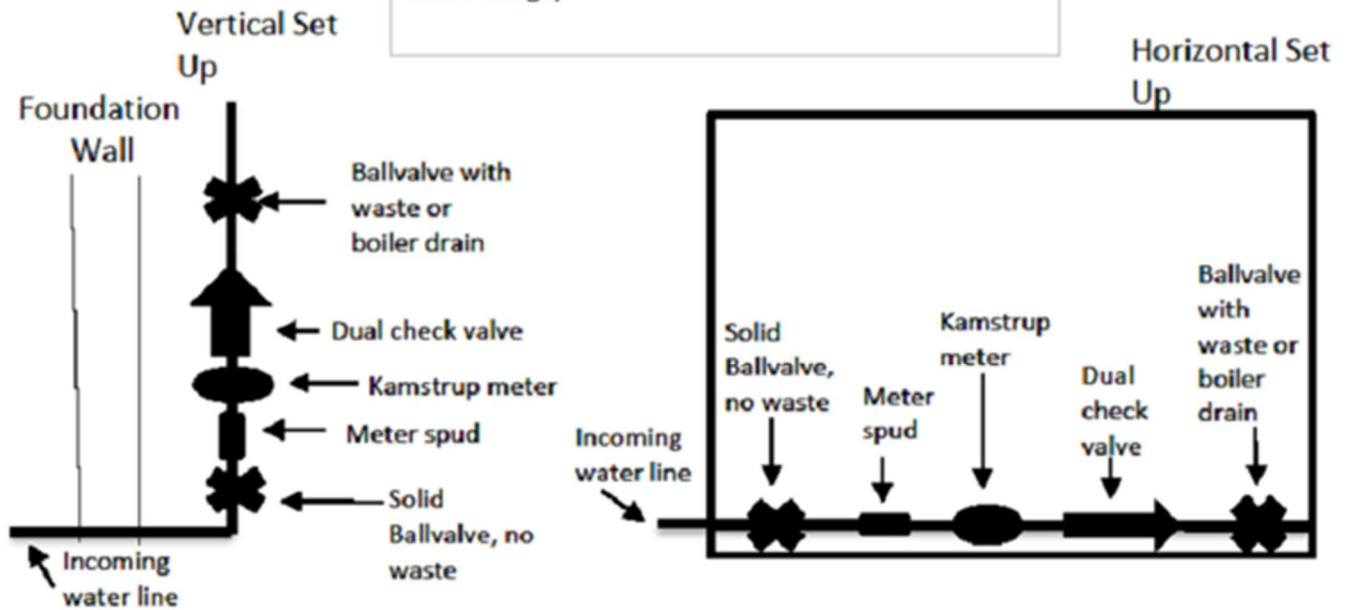

## New Meter Installation – Commercial

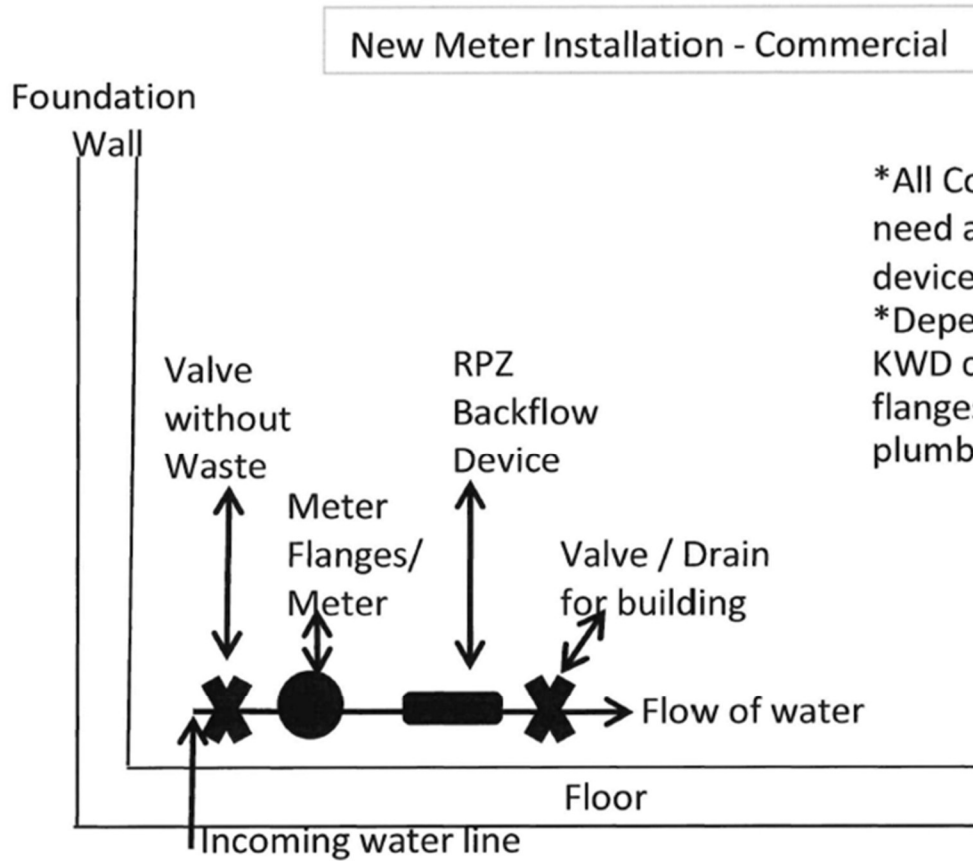

\*All Commercial properties need a testable RPZ backflow device.

\*Depending on size of meter, KWD can provide different flanges or tail pieces for the plumber.

## New Meter Installation – Eliot Deduct

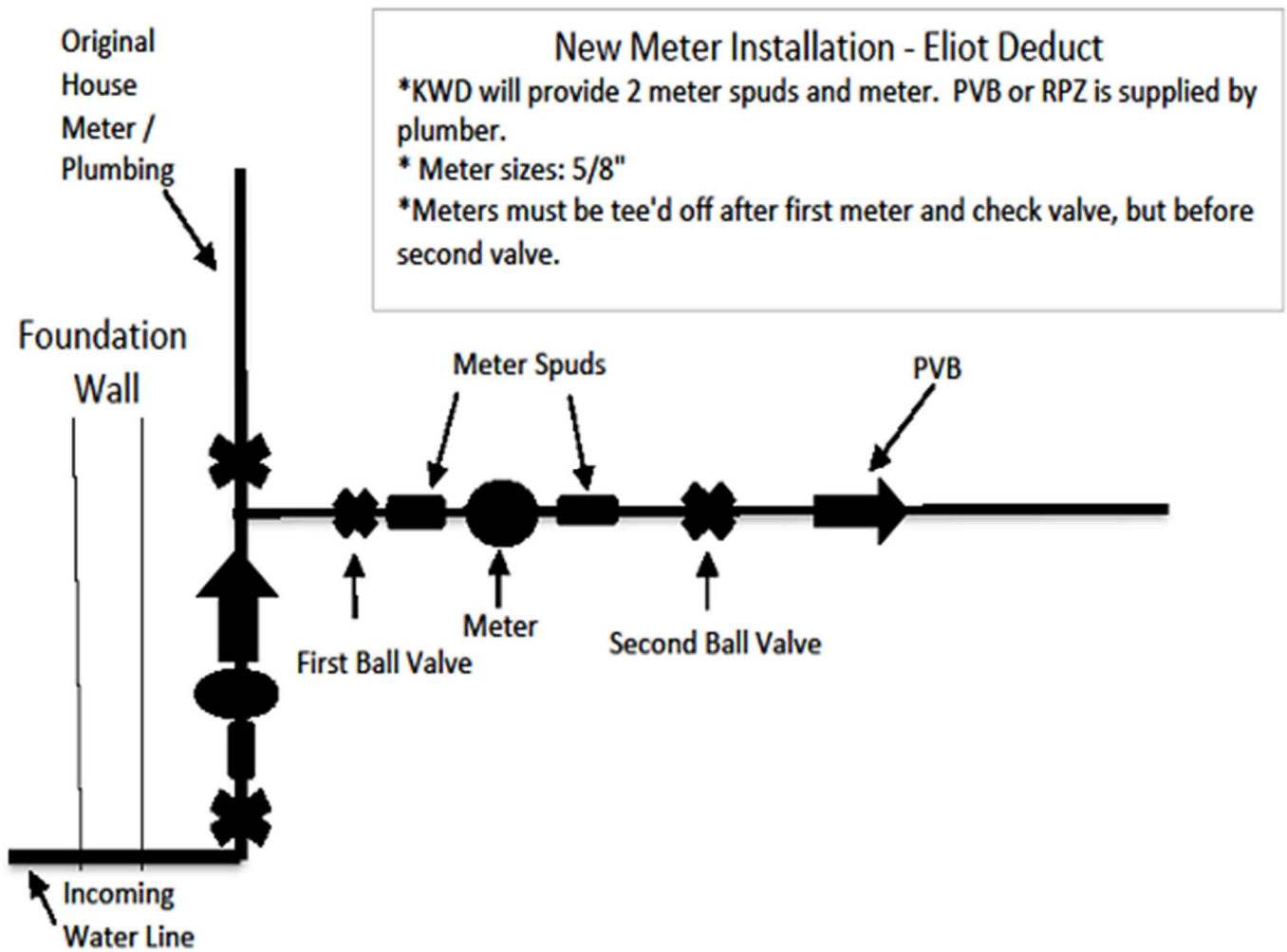

# New Meter Installation - Kittery Second Irrigation

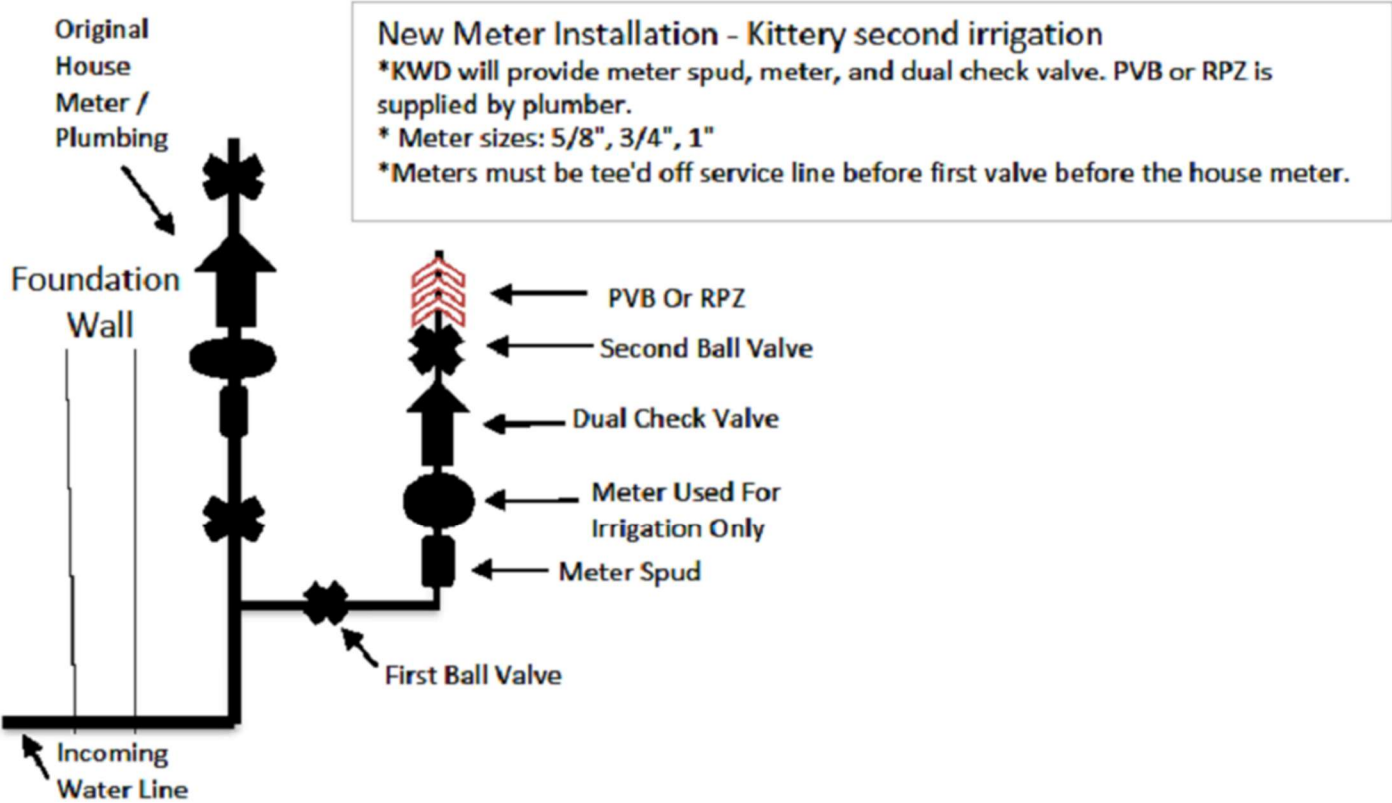

# KITTERY WATER DISTRICT

## WATER LINE CONSTRUCTION SPECIFICATIONS

APRIL 2026

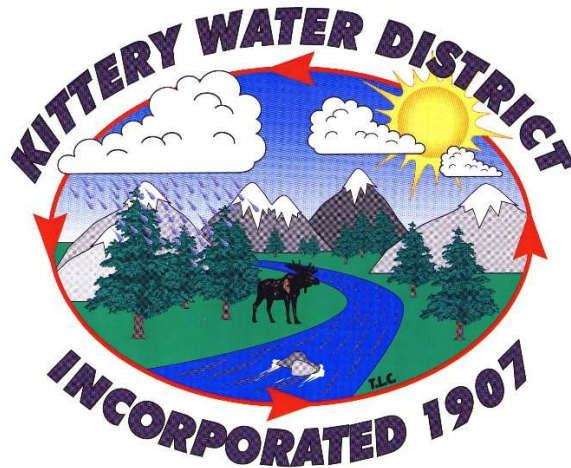

If you have any questions, please call the office at (207) 439-1128 or email at [info@kitterywater.org](mailto:info@kitterywater.org). Your inquiry will be directed to the appropriate staff member, who will follow up as quickly as is possible.

# Table of Contents

Introduction .....	3
Before Beginning Any Work .....	4
Installation Requirements.....	5
Water Line Construction Material Specifications.....	8
Standard 2 - Inch Blow Off Detail .....	11
New Meter Installation – Residential.....	12
New Meter Installation – Commercial.....	13
New Meter Installation – Eliot Deduct .....	14
New Meter Installation- Kittery Second Irrigation.....	15

## **Introduction**

This information is intended to inform and guide homeowners and contractors regarding procedures to follow while working on Kittery Water District (here after KWD) water lines. **This summary does not relieve the owner/contractor of the responsibility for meeting all State and Federal requirements pertaining to the installation of water and sewer lines.**

NOTE: Provided that both the material specifications and installation requirements of the KWD are followed, upon successful installation and testing of the underground and aboveground infrastructure, KWD will accept the ownership of the infrastructure for perpetuity. If the infrastructure is NOT located within the Town or State right-of-way, a Utility Easement will need to be issued to the KWD.

***NOTE: ALL PARTIES ARE STRONGLY ENCOURAGED TO READ THIS BOOKLET AND CALL WITH ANY QUESTIONS PRIOR TO STARTING WORK.***

*This information is subject to revision.*

## **Before Beginning Any Work**

1. The KWD requires **at least one week's notice** before any work can begin. This allows the KWD time to review the project with the owner/contractor and schedule installations and inspections, etc. **The owner/contractor must contact the KWD at (207) 439-1128 prior to beginning work.**
2. Pursuant to Federal Law, the owner/contractor must contact Dig Safe at 811, or 1-888-344-7233 at least three (3) working days prior to the date work is scheduled to begin. A Dig Safe Project Number is required prior to excavation.
3. The owner/contractor shall not operate any hydrants, valves or curb stops that are the property of the KWD, without the expressed permission of the KWD.
4. The owner/contractor shall be responsible for notifying all users/property owners affected, prior to shutting off any services. Appropriate agencies shall also be notified.

# **Installation Requirements**

## **INSPECTION SERVICES:**

Installation inspections will be performed by the District or its representative and paid for by the Developer or Contractor. Full time inspections will be performed by the District or its representative at the jobbing hourly rate. Inspections will be performed during regular business hours 7:00 am – 3:00 pm, Monday – Friday, unless a prior request is issued and approved by the KWD.

## **BEDDING AND BACKFILL:**

- Ledge must be fully excavated a minimum of 12” below and 12” on either side of the pipe.
- A Minimum of 6” of clean sand bedding under the pipe and 12” on either side of the pipe is required.
- Pipe Bedding – AWWA C600 Pipe Laying Sec. 4 standards shall be followed for the installations of water mains and appurtenances. Trenches shall be flat bottomed, with 6” of compacted clean sand beneath and 12” above the pipe. Where ledge is encountered, 12” of compacted clean sand shall be installed beneath the pipe. The trench will be kept dewatered during pipe laying.  
The pipe bedding shall be clean granular sand, free from organic matter, frozen material or any other objectionable material and shall meet the following requirement: 100% passing a 2” sieve.
- Stone Dust is NOT an acceptable substitute for sand.
- A Minimum of 12” of compacted sand above the pipe is required. Compaction can be accomplished by either the excavator bucket or a mechanical compactor.
- The remainder of the trench is to have compacted backfill material pre-approved by the District or its representative. Compaction of this material must be by a mechanical compactor.
- Minimum earth cover over the top of the pipe is 5’-0” (top of pipe to finish grade).
- Locking Tyton / Fastite gaskets shall be installed in the last 3 sections of pipe that is assembled before installing the blow-off assembly.
- The Blow-Off assembly will require that an MJ Tap Cap be installed which will require a spigot end of the pipe. (additional details below).
- Field cutting of pipe is not allowed within 3 feet of the bell of the pipe, unless the nominal O.D. of the pipe is maintained.

## **BLOW-OFF INSTALLATION (SEE DETAIL SHEETS):**

- High density polyethylene (H.D.P.E.) blow-offs are fabricated by KWD (time and material rates apply), and installed by the contractor.
- Valve shall be 2” ball valve, Riser shall be 2” H.D.P.E. plastic pipe.
- Contractor is responsible for backfilling once the Blow-Off and thrust blocks are installed.
- Sand backfill is required from the base of the valve and riser pipe to the top of the ground.
- Care must be taken not to dig beyond the blow-off installation area, such that thrust blocks can be set against undisturbed soil.
- 26” top flange valve box top sections and covers are to be installed over all Blow-Off assemblies, over the service box and over the riser pipe.

### **SERVICES LINE INSTALLATIONS:**

- Upon completion of the water main, and a passing pressure test, installation of services may be proceed.
- On Ductile mains, 1” direct taps will be performed, to a 1” cc Corp, to 1” “K” Copper Service Line, to a 1” Ballvalve Curb stop. The Curb stop will have a 36” s.s. Service Rod and a 4.5’-5.5’ Service Box. A Bibby with Cover labeled “Water” will be installed over the Service Box.
- On HDPE mains, 1” Service Saddles will be installed prior to tapping the main. A 1” cc Corp, to 1” CTS plastic Service Line, to a 1” Ballvalve Curb stop. The Curb stop will have a 36” s.s. Service Rod and a 4.5’-5.5’ Service Box. Tracer wire will be installed to the CTS line. A 6” top flange valve box top section with Cover labeled “WATER” will be installed over the Service Box.
- Clean sand bedding is also required 6” below the copper tubing and 12” to the sides and above. Sand backfill is also required around the service box, from the foot piece to the cap.
- Services that reach or exceed 150 feet from the curb stop will require a meter vault to be installed.

### **TEST SERVICE / CHLORINATION TAP:**

The KWD or Contractor shall install a 1” corporation and a CTS plastic riser with a 1” curb stop cnpj x feip, on the first length of water main that is installed, as close to the mainline valve as is practical. Upon successful completion of a pressure test, chlorination and a negative bacteria test, the Contractor shall excavate to allow removal of the test service and installation of a brass plug by either KWD or the Contractor (time and material rates apply).

### **FIRE HYDRANT INSTALLATIONS:**

- The traffic break flange of the hydrant shall not be less than 2” above the finish grade, nor more than 6” above the finish grade.
- Sand backfill is required around the barrel of the hydrant, from the shoe to the ground’s surface.
- Valve anchoring tees are to be used for all hydrant installations and lateral water mains.
- Marker poles will be provided by the District and installed by the contractor in the appropriate location (material rates apply).

### **WATER MAIN ACCEPTANCE POLICY:**

- The newly installed water main will be filled, flushed, hydrostatically tested and chlorinated by the contractor.
- A negative bacteria result is needed before the water is used for any reason. The contractor or KWD will take this sample and have it analyzed.
- An as-built drawing of the water main installation performed by a licensed surveyor or engineer is required before acceptance of the main by KWD.
- Receipt of an electronic version of the project plan.
- Acknowledgement and execution of any agreements (fire protection lines, fire hydrants, etc.).
- Execution of an Easement to the KWD, for any mains installed in non-public right of ways. This includes both the drafting and recording of the Easement.
- Payment shall be made to KWD for all invoiced services and materials.

## **METERS:**

- Meters are both supplied and installed by KWD (time and material rates apply).
- A sketch is available from the District, outlining the required plumbing setup to receive the meter.
- Type “L” Copper should be used in the installation.

## **NOTES:**

- All materials that are installed are to be made in the USA or Canada, unless otherwise approved by the KWD.
- Material Submittal Sheets (Cut Sheets) shall be submitted to the KWD for approvable prior purchasing the materials.
- Inspection and service work performed by KWD will be billed at the District’s current time and material rates. Services provided by a third party will be billed at their rate.
- The horizontal distance between water and sewer lines shall be a minimum of 10 feet. Anytime a sewer line crosses above a water main, one full section of typical sewer pipe must be replaced with a full section of SDR-21 quality pipe. The full section of SDR-21 pipe shall be centered upon the crossing to maximize joint distance from the watermain and shall have a minimum clearance of 18” above the watermain.
- During new construction groundwork, the Owner / Contractor is responsible for protecting any service or meter that may be in danger of freezing. Associated damage repair costs will be the responsibility of the Owner / Contractor.
- The installation of H.D.P.E. main and CTS Plastic service lines will require the installation of Copper Head Brand tracing wire and Snake Bite Brand connectors. The KWD has very specific requirements for the installation of the tracer wire. The on-site inspector will provide detailed guidance at the time of installation.
- GPK Products, Inc. Schedule 40 x SDR-35 G “No Stop” adaptors must be used for all SDR-35 to SDR-21 connections. Connections of SDR-21 to other types of sewer pipe shall use solid couplings. Flexible couplings will NOT be permitted.

# **Water Line Construction Material Specifications**

## **WATER MAIN:**

- Ductile Iron
- Class 52 thickness
- Tyton / Fastite joint
- Double cement lined
- Zinc coated

## **ALTERNATE WATER MAIN MATERIAL:**

- High Density Polyethylene (H.D.P.E.)
- SDR 11
- Butt Fusion / Electrofusion Couplings
- Blue Stripe
- Copper Head Brand tracer wire is required on the main and all laterals

## **DUCTILE IRON FITTINGS:**

- Class 350
- Made in the USA or Canada

## **DUCTILE IRON GATE VALVES:**

- 250 P.S.I. working pressure
- Open left
- Resilient wedge
- Valves 16" or greater must be Horizontal with Bevel Gear
- Stainless steel nuts and bolts
- Stainless steel or bronze operating nut
- Valve centering rings are required
- Mud plugs are required

## **FIRE HYDRANTS:**

- AFC Waterous Pacer WB 67
- Clow Medallion
- Kennedy Valve Guardian K81-D
- Open left
- Non draining barrel

## **SERVICE BOXES:**

- 4 ½' - 5 ½' height, cap with rope thread and pentagon nut

**VALVE BOXES:**

- Cast iron
- 36” top flange
- 36” bottom base belled (minimum length)
- 5 ¼” diameter
- Drop in cover with pick hole with the word “WATER” cast in the cover
- Made in the USA or Canada

**CORPORATIONS:**

- Minimum size 1” for residential
- Mac Pac compression style nut
- Ball construction
- AY McDonald or Ford brand
- CC thread type

**CURB STOPS:**

- Minimum size 1” for residential
- Mac Pac compression style nut
- Ball construction
- AY McDonald or Ford brand

**SERVICE LINES:**

- Service lines shall be K-copper tubing
- Minimum size of tubing is 1”
- CTS Plastic tubing may be used only when installing an H.D.P.E. main
- ALL service boxes are to be protected using a 5 ¼” x 6” valve box top extension with the cover stamped “WATER”

**STAINLESS STEEL SERVICE RODS:**

- 5/8” x 36” long, with Brass Cotter Pins

**TAPPING SLEEVE:**

- Series 304 stainless steel
- Ductile iron or stainless steel welded flange
- Size on size taps are NOT permitted on cast iron water mains

**RETAINER GLANDS:**

- Romac grip ring brand (R-Blue T-Bolts and nuts required)
- MJ Field Lok brand (R-Blue T-Bolts and nuts required)
- MEGA Lug brand (R-Blue T-Bolts and nuts required)

**SERVICE SADDLES:**

- Ductile Iron body
- Nylon coated body
- Double stainless steel straps
- Electrofusion service saddles with cc threads are required when using H.D.P.E. pipe



**2" Female Poly Cam Fitting with Plug, Valve Box Top Section and Cover.**

**KWD to provide 2" SDR Riser Pipe, and the Contractor will provide all other fittings per KWD detail**

**2" SDR 11 HDPE Riser (provided by the KWD)**

**2" Male Poly Cam Fitting, 2" Elbow, 2" x 12" Nipple, 2" FE x FE ball valve curb stop, 2" x 6" Nipple, 36" stainless steel rod, service box, Valve Box Top Section and Cover.**

**KITTERY WATER DISTRICT**  
**Standard 2 - Inch Blow Off Detail**

**This is a parts list beginning at the tapped MJ Cap or Plug:**

- 2" x 6" Brass Nipple
- 2" FE x FE Ball Valve Curb Stop
- 2" x 12" Brass Nipple
- 2" Brass Elbow
- 2" Male Poly Cam \*
- 2" SDR11 H.D.P.E. Pipe \*
- 2" Female Poly Cam \*
- 2" Brass Plug

**Also: After the assembly is installed:**

- Service Box Foot Piece
- Service Box (4' - 6" x 5' - 6")
- 36" x 5/8" Diameter Stainless Steel Service Rod
- Valve Box Cover (2)
- 26" Valve Box Top Section (2)

\* Riser Pipe is welded to the specified length by the Kittery Water District

## New Meter Installation – Residential

### New Meter Installation - Residential

\*KWD will provide meter spud, meter, and dual check valve.  
Meter sizes: 5/8", 3/4", 1" (Determined by water usage)

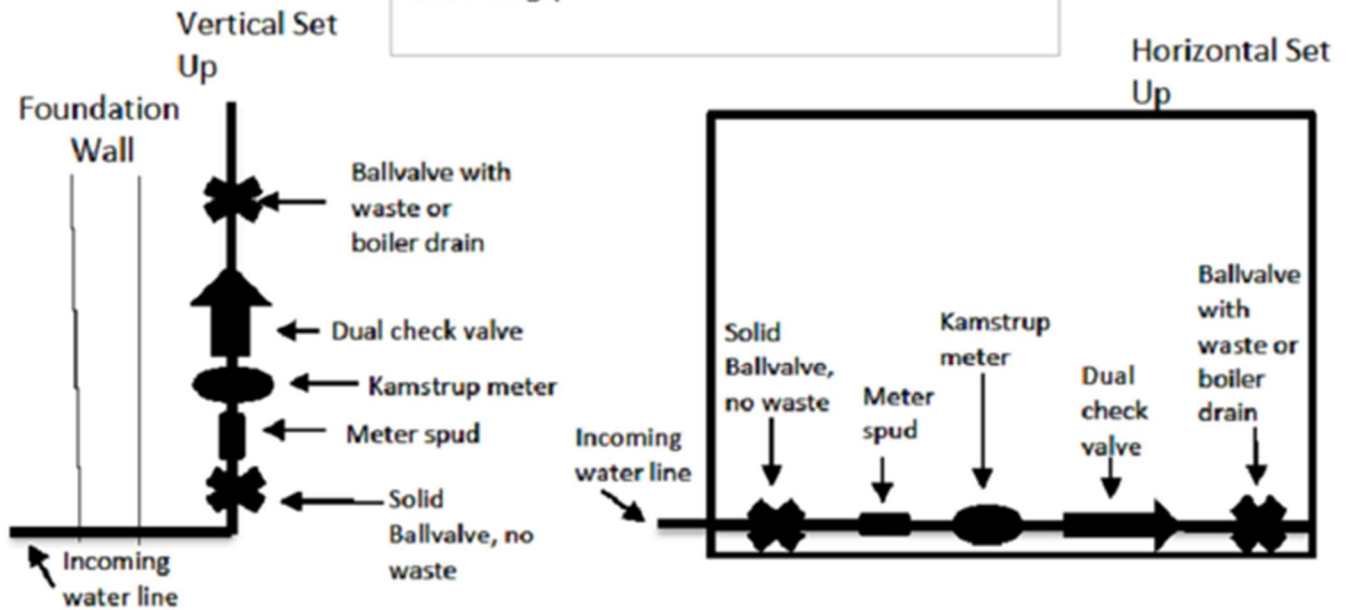

## New Meter Installation – Commercial

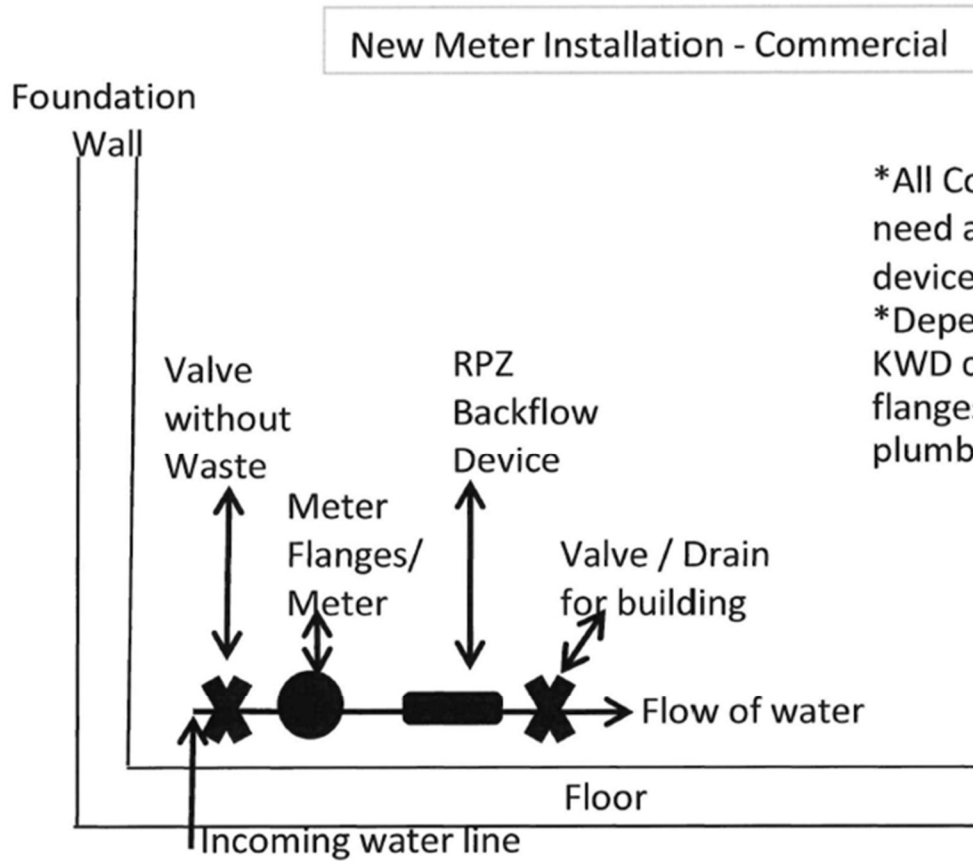

\*All Commercial properties need a testable RPZ backflow device.

\*Depending on size of meter, KWD can provide different flanges or tail pieces for the plumber.

## New Meter Installation – Eliot Deduct

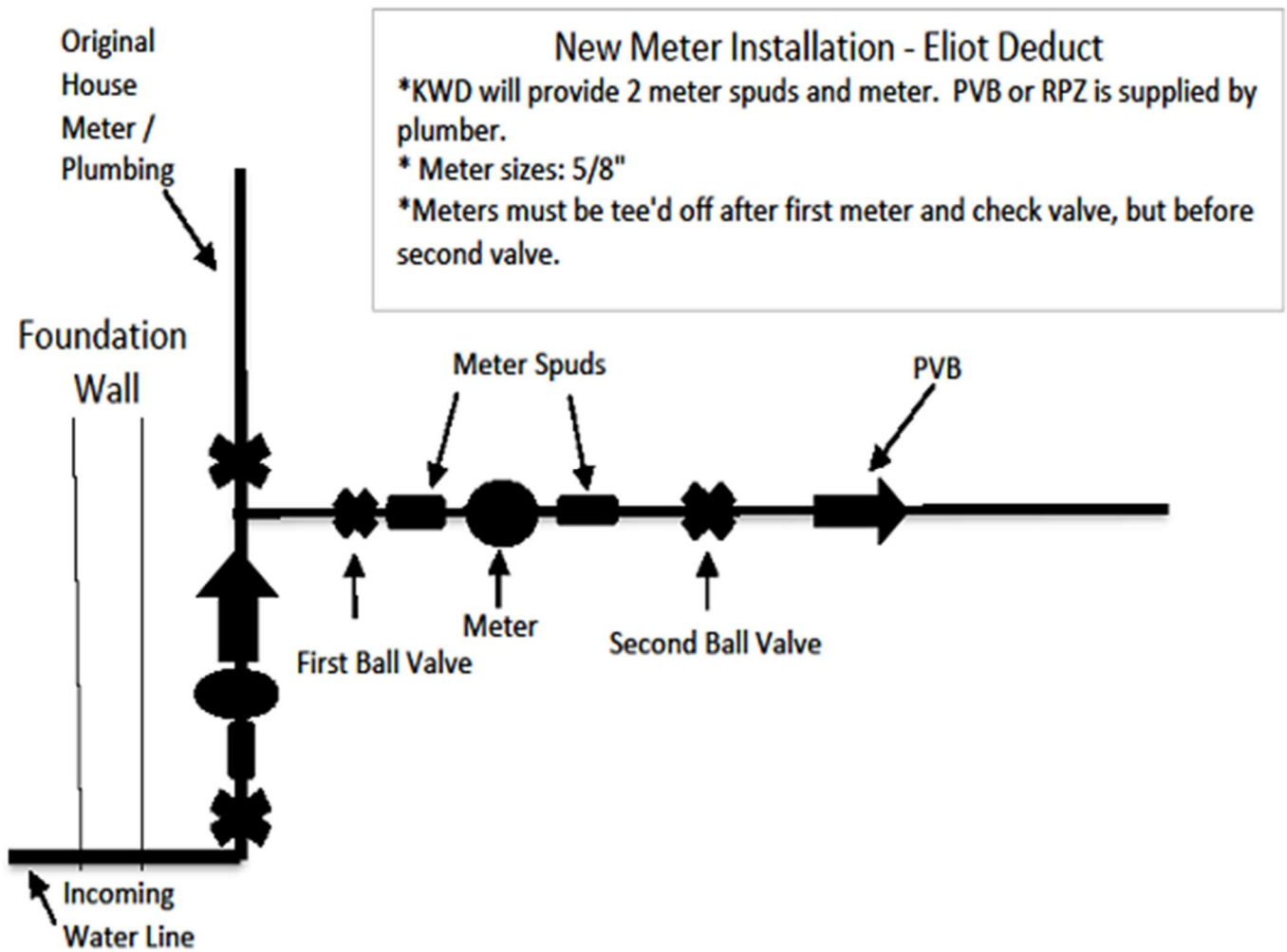

# New Meter Installation - Kittery Second Irrigation

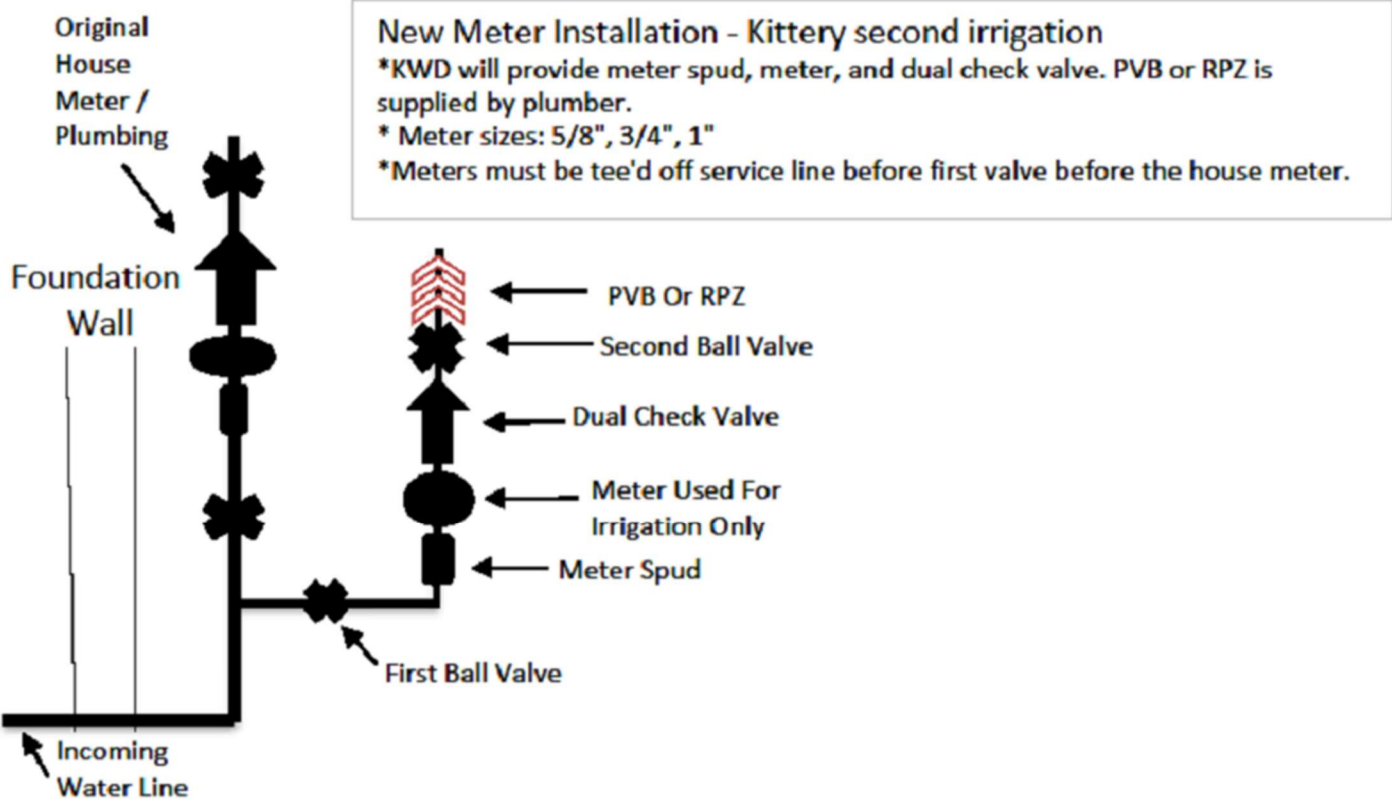

# KITTERY WATER DISTRICT

## WATER LINE CONSTRUCTION SPECIFICATIONS

APRIL 2026



If you have any questions, please call the office at (207) 439-1128 or email at [info@kitterywater.org](mailto:info@kitterywater.org). Your inquiry will be directed to the appropriate staff member, who will follow up as quickly as is possible.

# Table of Contents

Introduction .....	3
Before Beginning Any Work .....	4
Installation Requirements.....	5
Water Line Construction Material Specifications.....	8
Standard 2 - Inch Blow Off Detail .....	11
New Meter Installation – Residential.....	12
New Meter Installation – Commercial.....	13
New Meter Installation – Eliot Deduct .....	14
New Meter Installation- Kittery Second Irrigation.....	15

## **Introduction**

This information is intended to inform and guide homeowners and contractors regarding procedures to follow while working on Kittery Water District (here after KWD) water lines. **This summary does not relieve the owner/contractor of the responsibility for meeting all State and Federal requirements pertaining to the installation of water and sewer lines.**

NOTE: Provided that both the material specifications and installation requirements of the KWD are followed, upon successful installation and testing of the underground and aboveground infrastructure, KWD will accept the ownership of the infrastructure for perpetuity. If the infrastructure is NOT located within the Town or State right-of-way, a Utility Easement will need to be issued to the KWD.

***NOTE: ALL PARTIES ARE STRONGLY ENCOURAGED TO READ THIS BOOKLET AND CALL WITH ANY QUESTIONS PRIOR TO STARTING WORK.***

*This information is subject to revision.*

## **Before Beginning Any Work**

1. The KWD requires **at least one week's notice** before any work can begin. This allows the KWD time to review the project with the owner/contractor and schedule installations and inspections, etc. **The owner/contractor must contact the KWD at (207) 439-1128 prior to beginning work.**
2. Pursuant to Federal Law, the owner/contractor must contact Dig Safe at 811, or 1-888-344-7233 at least three (3) working days prior to the date work is scheduled to begin. A Dig Safe Project Number is required prior to excavation.
3. The owner/contractor shall not operate any hydrants, valves or curb stops that are the property of the KWD, without the expressed permission of the KWD.
4. The owner/contractor shall be responsible for notifying all users/property owners affected, prior to shutting off any services. Appropriate agencies shall also be notified.

# **Installation Requirements**

## **INSPECTION SERVICES:**

Installation inspections will be performed by the District or its representative and paid for by the Developer or Contractor. Full time inspections will be performed by the District or its representative at the jobbing hourly rate. Inspections will be performed during regular business hours 7:00 am – 3:00 pm, Monday – Friday, unless a prior request is issued and approved by the KWD.

## **BEDDING AND BACKFILL:**

- Ledge must be fully excavated a minimum of 12” below and 12” on either side of the pipe.
- A Minimum of 6” of clean sand bedding under the pipe and 12” on either side of the pipe is required.
- Pipe Bedding – AWWA C600 Pipe Laying Sec. 4 standards shall be followed for the installations of water mains and appurtenances. Trenches shall be flat bottomed, with 6” of compacted clean sand beneath and 12” above the pipe. Where ledge is encountered, 12” of compacted clean sand shall be installed beneath the pipe. The trench will be kept dewatered during pipe laying.  
The pipe bedding shall be clean granular sand, free from organic matter, frozen material or any other objectionable material and shall meet the following requirement: 100% passing a 2” sieve.
- Stone Dust is NOT an acceptable substitute for sand.
- A Minimum of 12” of compacted sand above the pipe is required. Compaction can be accomplished by either the excavator bucket or a mechanical compactor.
- The remainder of the trench is to have compacted backfill material pre-approved by the District or its representative. Compaction of this material must be by a mechanical compactor.
- Minimum earth cover over the top of the pipe is 5’-0” (top of pipe to finish grade).
- Locking Tyton / Fastite gaskets shall be installed in the last 3 sections of pipe that is assembled before installing the blow-off assembly.
- The Blow-Off assembly will require that an MJ Tap Cap be installed which will require a spigot end of the pipe. (additional details below).
- Field cutting of pipe is not allowed within 3 feet of the bell of the pipe, unless the nominal O.D. of the pipe is maintained.

## **BLOW-OFF INSTALLATION (SEE DETAIL SHEETS):**

- High density polyethylene (H.D.P.E.) blow-offs are fabricated by KWD (time and material rates apply), and installed by the contractor.
- Valve shall be 2” ball valve, Riser shall be 2” H.D.P.E. plastic pipe.
- Contractor is responsible for backfilling once the Blow-Off and thrust blocks are installed.
- Sand backfill is required from the base of the valve and riser pipe to the top of the ground.
- Care must be taken not to dig beyond the blow-off installation area, such that thrust blocks can be set against undisturbed soil.
- 26” top flange valve box top sections and covers are to be installed over all Blow-Off assemblies, over the service box and over the riser pipe.

### **SERVICES LINE INSTALLATIONS:**

- Upon completion of the water main, and a passing pressure test, installation of services may be proceed.
- On Ductile mains, 1" direct taps will be performed, to a 1" cc Corp, to 1" "K" Copper Service Line, to a 1" Ballvalve Curb stop. The Curb stop will have a 36" s.s. Service Rod and a 4.5'-5.5' Service Box. A Bibby with Cover labeled "Water" will be installed over the Service Box.
- On HDPE mains, 1" Service Saddles will be installed prior to tapping the main. A 1" cc Corp, to 1" CTS plastic Service Line, to a 1" Ballvalve Curb stop. The Curb stop will have a 36" s.s. Service Rod and a 4.5'-5.5' Service Box. Tracer wire will be installed to the CTS line. A 6" top flange valve box top section with Cover labeled "WATER" will be installed over the Service Box.
- Clean sand bedding is also required 6" below the copper tubing and 12" to the sides and above. Sand backfill is also required around the service box, from the foot piece to the cap.
- Services that reach or exceed 150 feet from the curb stop will require a meter vault to be installed.

### **TEST SERVICE / CHLORINATION TAP:**

The KWD or Contractor shall install a 1" corporation and a CTS plastic riser with a 1" curb stop cnpj x feip, on the first length of water main that is installed, as close to the mainline valve as is practical. Upon successful completion of a pressure test, chlorination and a negative bacteria test, the Contractor shall excavate to allow removal of the test service and installation of a brass plug by either KWD or the Contractor (time and material rates apply).

### **FIRE HYDRANT INSTALLATIONS:**

- The traffic break flange of the hydrant shall not be less than 2" above the finish grade, nor more than 6" above the finish grade.
- Sand backfill is required around the barrel of the hydrant, from the shoe to the ground's surface.
- Valve anchoring tees are to be used for all hydrant installations and lateral water mains.
- Marker poles will be provided by the District and installed by the contractor in the appropriate location (material rates apply).

### **WATER MAIN ACCEPTANCE POLICY:**

- The newly installed water main will be filled, flushed, hydrostatically tested and chlorinated by the contractor.
- A negative bacteria result is needed before the water is used for any reason. The contractor or KWD will take this sample and have it analyzed.
- An as-built drawing of the water main installation performed by a licensed surveyor or engineer is required before acceptance of the main by KWD.
- Receipt of an electronic version of the project plan.
- Acknowledgement and execution of any agreements (fire protection lines, fire hydrants, etc.).
- Execution of an Easement to the KWD, for any mains installed in non-public right of ways. This includes both the drafting and recording of the Easement.
- Payment shall be made to KWD for all invoiced services and materials.

## **METERS:**

- Meters are both supplied and installed by KWD (time and material rates apply).
- A sketch is available from the District, outlining the required plumbing setup to receive the meter.
- Type “L” Copper should be used in the installation.

## **NOTES:**

- All materials that are installed are to be made in the USA or Canada, unless otherwise approved by the KWD.
- Material Submittal Sheets (Cut Sheets) shall be submitted to the KWD for approvable prior purchasing the materials.
- Inspection and service work performed by KWD will be billed at the District’s current time and material rates. Services provided by a third party will be billed at their rate.
- The horizontal distance between water and sewer lines shall be a minimum of 10 feet. Anytime a sewer line crosses above a water main, one full section of typical sewer pipe must be replaced with a full section of SDR-21 quality pipe. The full section of SDR-21 pipe shall be centered upon the crossing to maximize joint distance from the watermain and shall have a minimum clearance of 18” above the watermain.
- During new construction groundwork, the Owner / Contractor is responsible for protecting any service or meter that may be in danger of freezing. Associated damage repair costs will be the responsibility of the Owner / Contractor.
- The installation of H.D.P.E. main and CTS Plastic service lines will require the installation of Copper Head Brand tracing wire and Snake Bite Brand connectors. The KWD has very specific requirements for the installation of the tracer wire. The on-site inspector will provide detailed guidance at the time of installation.
- GPK Products, Inc. Schedule 40 x SDR-35 G “No Stop” adaptors must be used for all SDR-35 to SDR-21 connections. Connections of SDR-21 to other types of sewer pipe shall use solid couplings. Flexible couplings will NOT be permitted.

# **Water Line Construction Material Specifications**

## **WATER MAIN:**

- Ductile Iron
- Class 52 thickness
- Tyton / Fastite joint
- Double cement lined
- Zinc coated

## **ALTERNATE WATER MAIN MATERIAL:**

- High Density Polyethylene (H.D.P.E.)
- SDR 11
- Butt Fusion / Electrofusion Couplings
- Blue Stripe
- Copper Head Brand tracer wire is required on the main and all laterals

## **DUCTILE IRON FITTINGS:**

- Class 350
- Made in the USA or Canada

## **DUCTILE IRON GATE VALVES:**

- 250 P.S.I. working pressure
- Open left
- Resilient wedge
- Valves 16" or greater must be Horizontal with Bevel Gear
- Stainless steel nuts and bolts
- Stainless steel or bronze operating nut
- Valve centering rings are required
- Mud plugs are required

## **FIRE HYDRANTS:**

- AFC Waterous Pacer WB 67
- Clow Medallion
- Kennedy Valve Guardian K81-D
- Open left
- Non draining barrel

## **SERVICE BOXES:**

- 4 ½' - 5 ½' height, cap with rope thread and pentagon nut

**VALVE BOXES:**

- Cast iron
- 36” top flange
- 36” bottom base belled (minimum length)
- 5 ¼” diameter
- Drop in cover with pick hole with the word “WATER” cast in the cover
- Made in the USA or Canada

**CORPORATIONS:**

- Minimum size 1” for residential
- Mac Pac compression style nut
- Ball construction
- AY McDonald or Ford brand
- CC thread type

**CURB STOPS:**

- Minimum size 1” for residential
- Mac Pac compression style nut
- Ball construction
- AY McDonald or Ford brand

**SERVICE LINES:**

- Service lines shall be K-copper tubing
- Minimum size of tubing is 1”
- CTS Plastic tubing may be used only when installing an H.D.P.E. main
- ALL service boxes are to be protected using a 5 ¼” x 6” valve box top extension with the cover stamped “WATER”

**STAINLESS STEEL SERVICE RODS:**

- 5/8” x 36” long, with Brass Cotter Pins

**TAPPING SLEEVE:**

- Series 304 stainless steel
- Ductile iron or stainless steel welded flange
- Size on size taps are NOT permitted on cast iron water mains

**RETAINER GLANDS:**

- Romac grip ring brand (R-Blue T-Bolts and nuts required)
- MJ Field Lok brand (R-Blue T-Bolts and nuts required)
- MEGA Lug brand (R-Blue T-Bolts and nuts required)

**SERVICE SADDLES:**

- Ductile Iron body
- Nylon coated body
- Double stainless steel straps
- Electrofusion service saddles with cc threads are required when using H.D.P.E. pipe



**2" Female Poly Cam Fitting with Plug, Valve Box Top Section and Cover.**

**KWD to provide 2" SDR Riser Pipe, and the Contractor will provide all other fittings per KWD detail**

**2" SDR 11 HDPE Riser (provided by the KWD)**

**2" Male Poly Cam Fitting, 2" Elbow, 2" x 12" Nipple, 2" FE x FE ball valve curb stop, 2" x 6" Nipple, 36" stainless steel rod, service box, Valve Box Top Section and Cover.**

**KITTERY WATER DISTRICT**  
**Standard 2 - Inch Blow Off Detail**

**This is a parts list beginning at the tapped MJ Cap or Plug:**

- 2" x 6" Brass Nipple
- 2" FE x FE Ball Valve Curb Stop
- 2" x 12" Brass Nipple
- 2" Brass Elbow
- 2" Male Poly Cam \*
- 2" SDR11 H.D.P.E. Pipe \*
- 2" Female Poly Cam \*
- 2" Brass Plug

**Also: After the assembly is installed:**

- Service Box Foot Piece
- Service Box (4' - 6" x 5' - 6")
- 36" x 5/8" Diameter Stainless Steel Service Rod
- Valve Box Cover (2)
- 26" Valve Box Top Section (2)

\* Riser Pipe is welded to the specified length by the Kittery Water District

## New Meter Installation – Residential

### New Meter Installation - Residential

\*KWD will provide meter spud, meter, and dual check valve.  
Meter sizes: 5/8", 3/4", 1" (Determined by water usage)

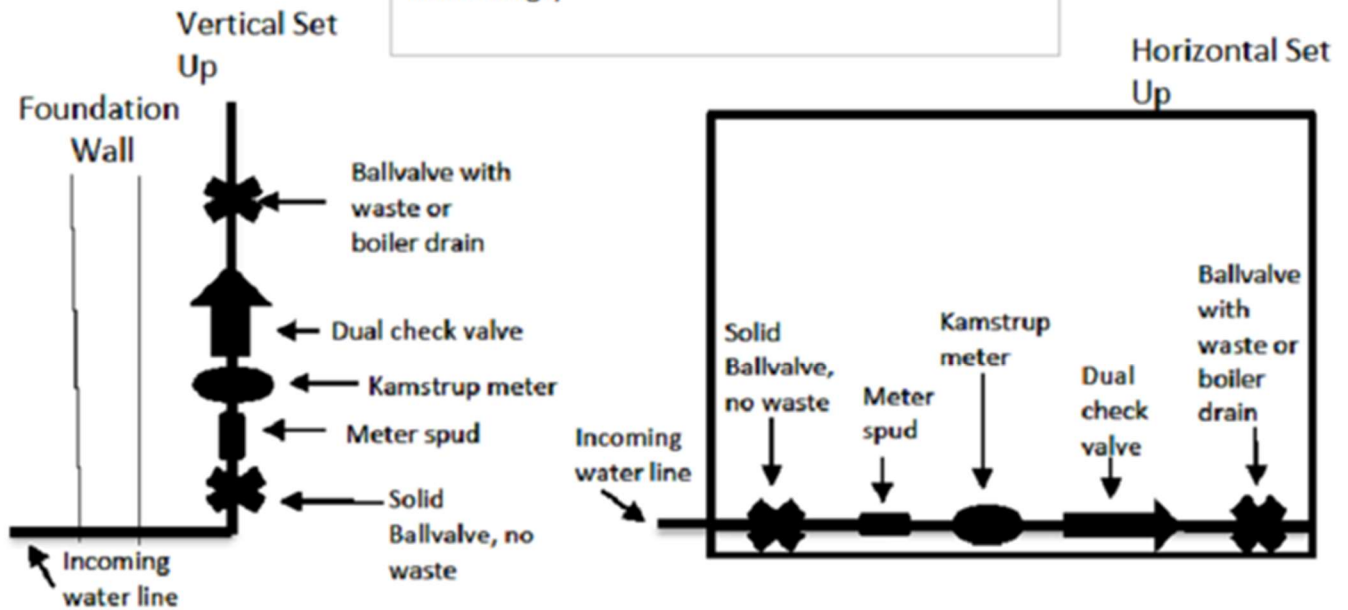

## New Meter Installation – Commercial

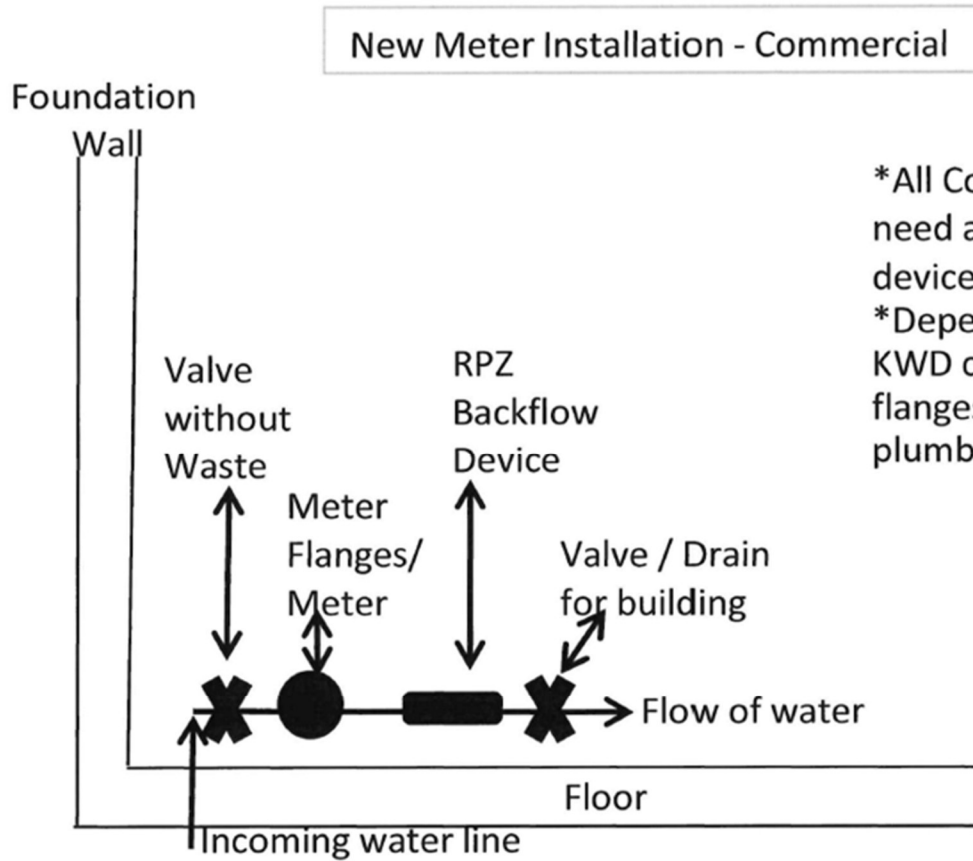

\*All Commercial properties need a testable RPZ backflow device.

\*Depending on size of meter, KWD can provide different flanges or tail pieces for the plumber.

## New Meter Installation – Eliot Deduct

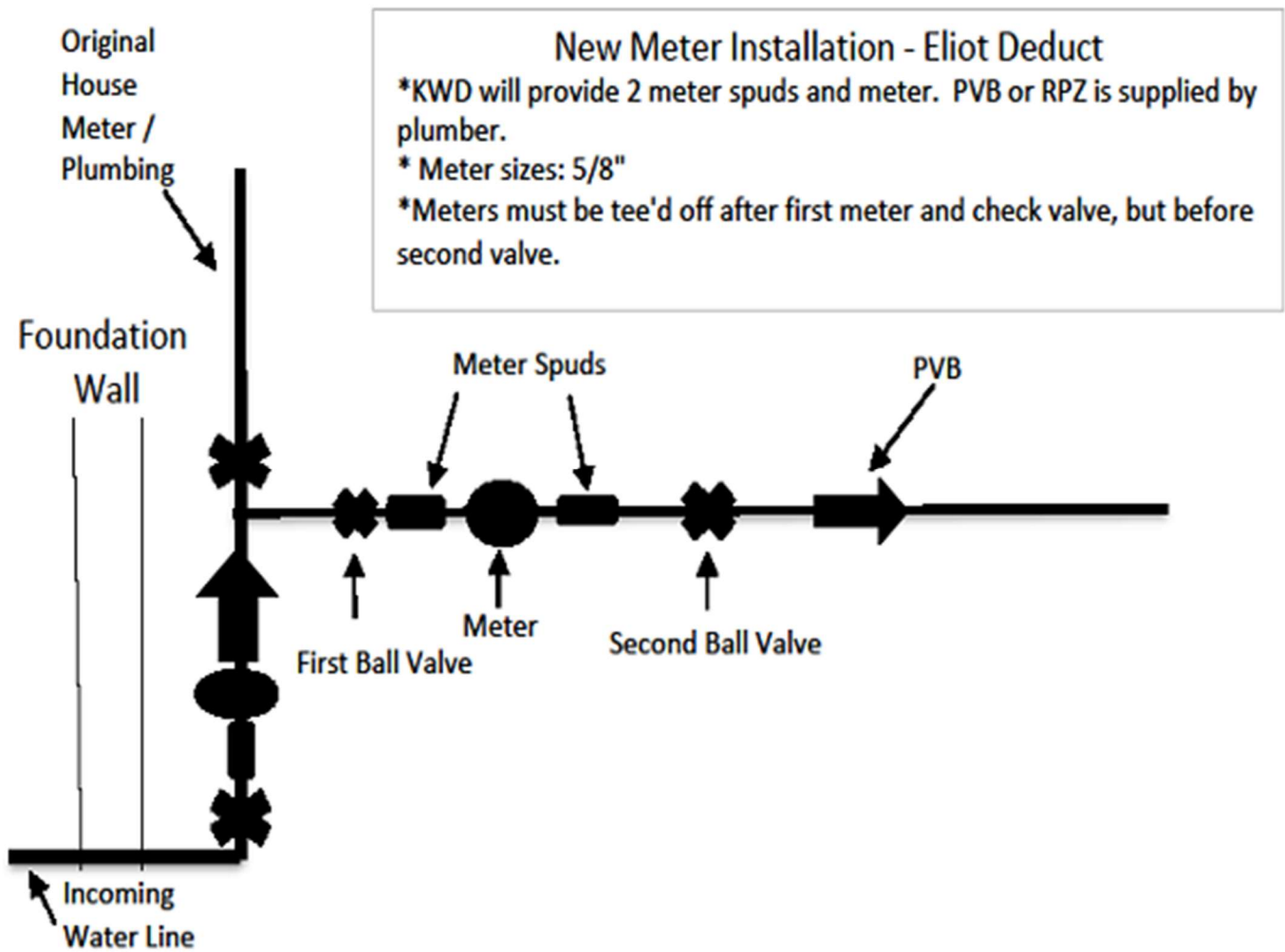

# New Meter Installation - Kittery Second Irrigation

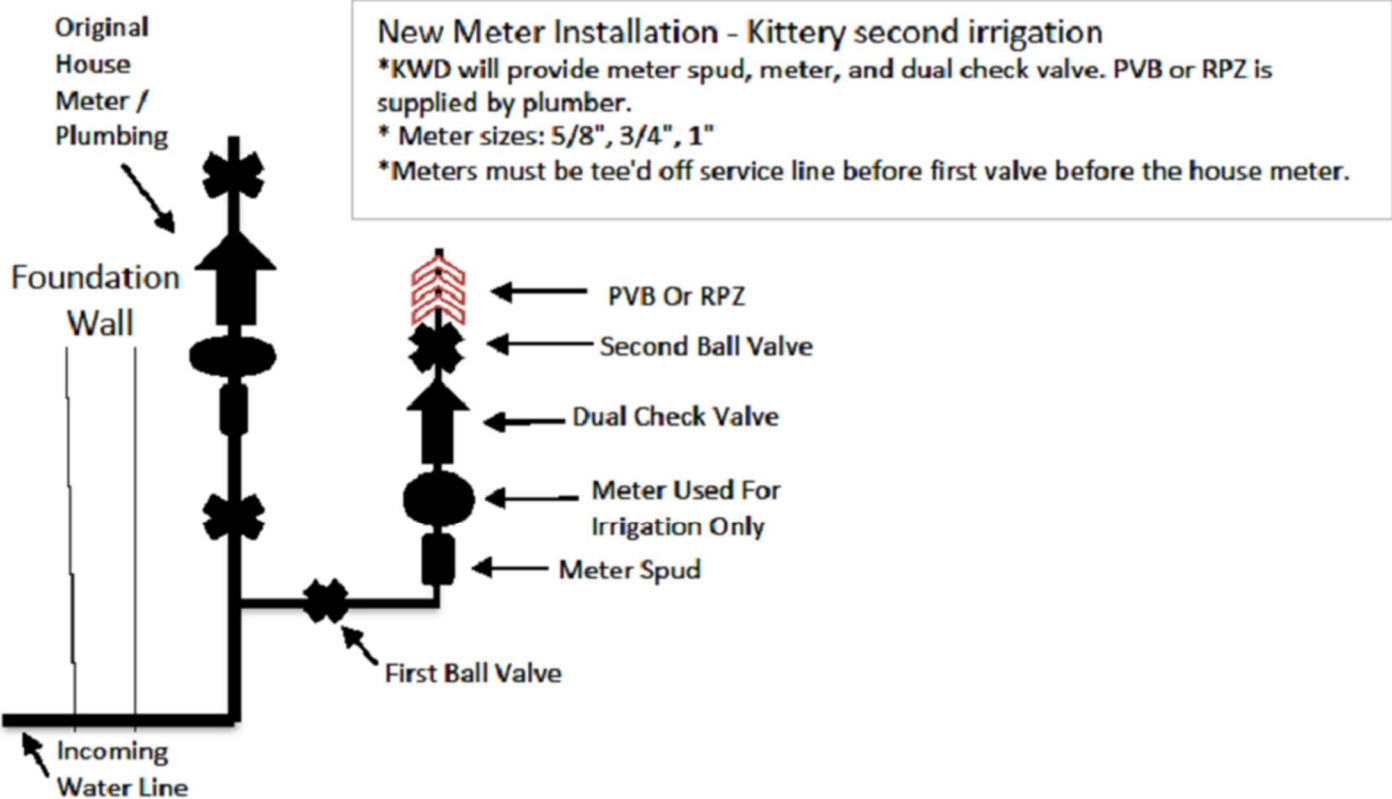

# KITTERY WATER DISTRICT

## WATER LINE CONSTRUCTION SPECIFICATIONS

APRIL 2026



If you have any questions, please call the office at (207) 439-1128 or email at [info@kitterywater.org](mailto:info@kitterywater.org). Your inquiry will be directed to the appropriate staff member, who will follow up as quickly as is possible.

# Table of Contents

Introduction .....	3
Before Beginning Any Work .....	4
Installation Requirements.....	5
Water Line Construction Material Specifications.....	8
Standard 2 - Inch Blow Off Detail .....	11
New Meter Installation – Residential.....	12
New Meter Installation – Commercial.....	13
New Meter Installation – Eliot Deduct .....	14
New Meter Installation- Kittery Second Irrigation.....	15

## **Introduction**

This information is intended to inform and guide homeowners and contractors regarding procedures to follow while working on Kittery Water District (here after KWD) water lines. **This summary does not relieve the owner/contractor of the responsibility for meeting all State and Federal requirements pertaining to the installation of water and sewer lines.**

NOTE: Provided that both the material specifications and installation requirements of the KWD are followed, upon successful installation and testing of the underground and aboveground infrastructure, KWD will accept the ownership of the infrastructure for perpetuity. If the infrastructure is NOT located within the Town or State right-of-way, a Utility Easement will need to be issued to the KWD.

***NOTE: ALL PARTIES ARE STRONGLY ENCOURAGED TO READ THIS BOOKLET AND CALL WITH ANY QUESTIONS PRIOR TO STARTING WORK.***

*This information is subject to revision.*

## **Before Beginning Any Work**

1. The KWD requires **at least one week's notice** before any work can begin. This allows the KWD time to review the project with the owner/contractor and schedule installations and inspections, etc. **The owner/contractor must contact the KWD at (207) 439-1128 prior to beginning work.**
2. Pursuant to Federal Law, the owner/contractor must contact Dig Safe at 811, or 1-888-344-7233 at least three (3) working days prior to the date work is scheduled to begin. A Dig Safe Project Number is required prior to excavation.
3. The owner/contractor shall not operate any hydrants, valves or curb stops that are the property of the KWD, without the expressed permission of the KWD.
4. The owner/contractor shall be responsible for notifying all users/property owners affected, prior to shutting off any services. Appropriate agencies shall also be notified.

# **Installation Requirements**

## **INSPECTION SERVICES:**

Installation inspections will be performed by the District or its representative and paid for by the Developer or Contractor. Full time inspections will be performed by the District or its representative at the jobbing hourly rate. Inspections will be performed during regular business hours 7:00 am – 3:00 pm, Monday – Friday, unless a prior request is issued and approved by the KWD.

## **BEDDING AND BACKFILL:**

- Ledge must be fully excavated a minimum of 12” below and 12” on either side of the pipe.
- A Minimum of 6” of clean sand bedding under the pipe and 12” on either side of the pipe is required.
- Pipe Bedding – AWWA C600 Pipe Laying Sec. 4 standards shall be followed for the installations of water mains and appurtenances. Trenches shall be flat bottomed, with 6” of compacted clean sand beneath and 12” above the pipe. Where ledge is encountered, 12” of compacted clean sand shall be installed beneath the pipe. The trench will be kept dewatered during pipe laying.  
The pipe bedding shall be clean granular sand, free from organic matter, frozen material or any other objectionable material and shall meet the following requirement: 100% passing a 2” sieve.
- Stone Dust is NOT an acceptable substitute for sand.
- A Minimum of 12” of compacted sand above the pipe is required. Compaction can be accomplished by either the excavator bucket or a mechanical compactor.
- The remainder of the trench is to have compacted backfill material pre-approved by the District or its representative. Compaction of this material must be by a mechanical compactor.
- Minimum earth cover over the top of the pipe is 5’-0” (top of pipe to finish grade).
- Locking Tyton / Fastite gaskets shall be installed in the last 3 sections of pipe that is assembled before installing the blow-off assembly.
- The Blow-Off assembly will require that an MJ Tap Cap be installed which will require a spigot end of the pipe. (additional details below).
- Field cutting of pipe is not allowed within 3 feet of the bell of the pipe, unless the nominal O.D. of the pipe is maintained.

## **BLOW-OFF INSTALLATION (SEE DETAIL SHEETS):**

- High density polyethylene (H.D.P.E.) blow-offs are fabricated by KWD (time and material rates apply), and installed by the contractor.
- Valve shall be 2” ball valve, Riser shall be 2” H.D.P.E. plastic pipe.
- Contractor is responsible for backfilling once the Blow-Off and thrust blocks are installed.
- Sand backfill is required from the base of the valve and riser pipe to the top of the ground.
- Care must be taken not to dig beyond the blow-off installation area, such that thrust blocks can be set against undisturbed soil.
- 26” top flange valve box top sections and covers are to be installed over all Blow-Off assemblies, over the service box and over the riser pipe.

### **SERVICES LINE INSTALLATIONS:**

- Upon completion of the water main, and a passing pressure test, installation of services may be proceed.
- On Ductile mains, 1" direct taps will be performed, to a 1" cc Corp, to 1" "K" Copper Service Line, to a 1" Ballvalve Curb stop. The Curb stop will have a 36" s.s. Service Rod and a 4.5'-5.5' Service Box. A Bibby with Cover labeled "Water" will be installed over the Service Box.
- On HDPE mains, 1" Service Saddles will be installed prior to tapping the main. A 1" cc Corp, to 1" CTS plastic Service Line, to a 1" Ballvalve Curb stop. The Curb stop will have a 36" s.s. Service Rod and a 4.5'-5.5' Service Box. Tracer wire will be installed to the CTS line. A 6" top flange valve box top section with Cover labeled "WATER" will be installed over the Service Box.
- Clean sand bedding is also required 6" below the copper tubing and 12" to the sides and above. Sand backfill is also required around the service box, from the foot piece to the cap.
- Services that reach or exceed 150 feet from the curb stop will require a meter vault to be installed.

### **TEST SERVICE / CHLORINATION TAP:**

The KWD or Contractor shall install a 1" corporation and a CTS plastic riser with a 1" curb stop cnpj x feip, on the first length of water main that is installed, as close to the mainline valve as is practical. Upon successful completion of a pressure test, chlorination and a negative bacteria test, the Contractor shall excavate to allow removal of the test service and installation of a brass plug by either KWD or the Contractor (time and material rates apply).

### **FIRE HYDRANT INSTALLATIONS:**

- The traffic break flange of the hydrant shall not be less than 2" above the finish grade, nor more than 6" above the finish grade.
- Sand backfill is required around the barrel of the hydrant, from the shoe to the ground's surface.
- Valve anchoring tees are to be used for all hydrant installations and lateral water mains.
- Marker poles will be provided by the District and installed by the contractor in the appropriate location (material rates apply).

### **WATER MAIN ACCEPTANCE POLICY:**

- The newly installed water main will be filled, flushed, hydrostatically tested and chlorinated by the contractor.
- A negative bacteria result is needed before the water is used for any reason. The contractor or KWD will take this sample and have it analyzed.
- An as-built drawing of the water main installation performed by a licensed surveyor or engineer is required before acceptance of the main by KWD.
- Receipt of an electronic version of the project plan.
- Acknowledgement and execution of any agreements (fire protection lines, fire hydrants, etc.).
- Execution of an Easement to the KWD, for any mains installed in non-public right of ways. This includes both the drafting and recording of the Easement.
- Payment shall be made to KWD for all invoiced services and materials.

## **METERS:**

- Meters are both supplied and installed by KWD (time and material rates apply).
- A sketch is available from the District, outlining the required plumbing setup to receive the meter.
- Type “L” Copper should be used in the installation.

## **NOTES:**

- All materials that are installed are to be made in the USA or Canada, unless otherwise approved by the KWD.
- Material Submittal Sheets (Cut Sheets) shall be submitted to the KWD for approvable prior purchasing the materials.
- Inspection and service work performed by KWD will be billed at the District’s current time and material rates. Services provided by a third party will be billed at their rate.
- The horizontal distance between water and sewer lines shall be a minimum of 10 feet. Anytime a sewer line crosses above a water main, one full section of typical sewer pipe must be replaced with a full section of SDR-21 quality pipe. The full section of SDR-21 pipe shall be centered upon the crossing to maximize joint distance from the watermain and shall have a minimum clearance of 18” above the watermain.
- During new construction groundwork, the Owner / Contractor is responsible for protecting any service or meter that may be in danger of freezing. Associated damage repair costs will be the responsibility of the Owner / Contractor.
- The installation of H.D.P.E. main and CTS Plastic service lines will require the installation of Copper Head Brand tracing wire and Snake Bite Brand connectors. The KWD has very specific requirements for the installation of the tracer wire. The on-site inspector will provide detailed guidance at the time of installation.
- GPK Products, Inc. Schedule 40 x SDR-35 G “No Stop” adaptors must be used for all SDR-35 to SDR-21 connections. Connections of SDR-21 to other types of sewer pipe shall use solid couplings. Flexible couplings will NOT be permitted.

# **Water Line Construction Material Specifications**

## **WATER MAIN:**

- Ductile Iron
- Class 52 thickness
- Tyton / Fastite joint
- Double cement lined
- Zinc coated

## **ALTERNATE WATER MAIN MATERIAL:**

- High Density Polyethylene (H.D.P.E.)
- SDR 11
- Butt Fusion / Electrofusion Couplings
- Blue Stripe
- Copper Head Brand tracer wire is required on the main and all laterals

## **DUCTILE IRON FITTINGS:**

- Class 350
- Made in the USA or Canada

## **DUCTILE IRON GATE VALVES:**

- 250 P.S.I. working pressure
- Open left
- Resilient wedge
- Valves 16" or greater must be Horizontal with Bevel Gear
- Stainless steel nuts and bolts
- Stainless steel or bronze operating nut
- Valve centering rings are required
- Mud plugs are required

## **FIRE HYDRANTS:**

- AFC Waterous Pacer WB 67
- Clow Medallion
- Kennedy Valve Guardian K81-D
- Open left
- Non draining barrel

## **SERVICE BOXES:**

- 4 ½' - 5 ½' height, cap with rope thread and pentagon nut

**VALVE BOXES:**

- Cast iron
- 36” top flange
- 36” bottom base belled (minimum length)
- 5 ¼” diameter
- Drop in cover with pick hole with the word “WATER” cast in the cover
- Made in the USA or Canada

**CORPORATIONS:**

- Minimum size 1” for residential
- Mac Pac compression style nut
- Ball construction
- AY McDonald or Ford brand
- CC thread type

**CURB STOPS:**

- Minimum size 1” for residential
- Mac Pac compression style nut
- Ball construction
- AY McDonald or Ford brand

**SERVICE LINES:**

- Service lines shall be K-copper tubing
- Minimum size of tubing is 1”
- CTS Plastic tubing may be used only when installing an H.D.P.E. main
- ALL service boxes are to be protected using a 5 ¼” x 6” valve box top extension with the cover stamped “WATER”

**STAINLESS STEEL SERVICE RODS:**

- 5/8” x 36” long, with Brass Cotter Pins

**TAPPING SLEEVE:**

- Series 304 stainless steel
- Ductile iron or stainless steel welded flange
- Size on size taps are NOT permitted on cast iron water mains

**RETAINER GLANDS:**

- Romac grip ring brand (R-Blue T-Bolts and nuts required)
- MJ Field Lok brand (R-Blue T-Bolts and nuts required)
- MEGA Lug brand (R-Blue T-Bolts and nuts required)

**SERVICE SADDLES:**

- Ductile Iron body
- Nylon coated body
- Double stainless steel straps
- Electrofusion service saddles with cc threads are required when using H.D.P.E. pipe



**2" Female Poly  
Cam Fitting with  
Plug, Valve Box  
Top Section and  
Cover.**

**KWD to provide 2" SDR  
Riser Pipe, and the  
Contractor will provide  
all other fittings per  
KWD detail**

**2" SDR 11 HDPE  
Riser (provided  
by the KWD)**

**2" Male Poly Cam  
Fitting, 2" Elbow, 2"  
x 12" Nipple, 2" FE x  
FE ball valve curb  
stop, 2" x 6" Nipple,  
36" stainless steel  
rod, service box,  
Valve Box Top  
Section and Cover.**

# **KITTERY WATER DISTRICT**

## **Standard 2 - Inch Blow Off Detail**

### **This is a parts list beginning at the tapped MJ Cap or Plug:**

- 2" x 6" Brass Nipple
- 2" FE x FE Ball Valve Curb Stop
- 2" x 12" Brass Nipple
- 2" Brass Elbow
- 2" Male Poly Cam \*
- 2" SDR11 H.D.P.E. Pipe \*
- 2" Female Poly Cam \*
- 2" Brass Plug

### **Also: After the assembly is installed:**

- Service Box Foot Piece
- Service Box (4' - 6" x 5' - 6")
- 36" x 5/8" Diameter Stainless Steel Service Rod
- Valve Box Cover (2)
- 26" Valve Box Top Section (2)

\* Riser Pipe is welded to the specified length by the Kittery Water District

## New Meter Installation – Residential

### New Meter Installation - Residential

\*KWD will provide meter spud, meter, and dual check valve.  
Meter sizes: 5/8", 3/4", 1" (Determined by water usage)

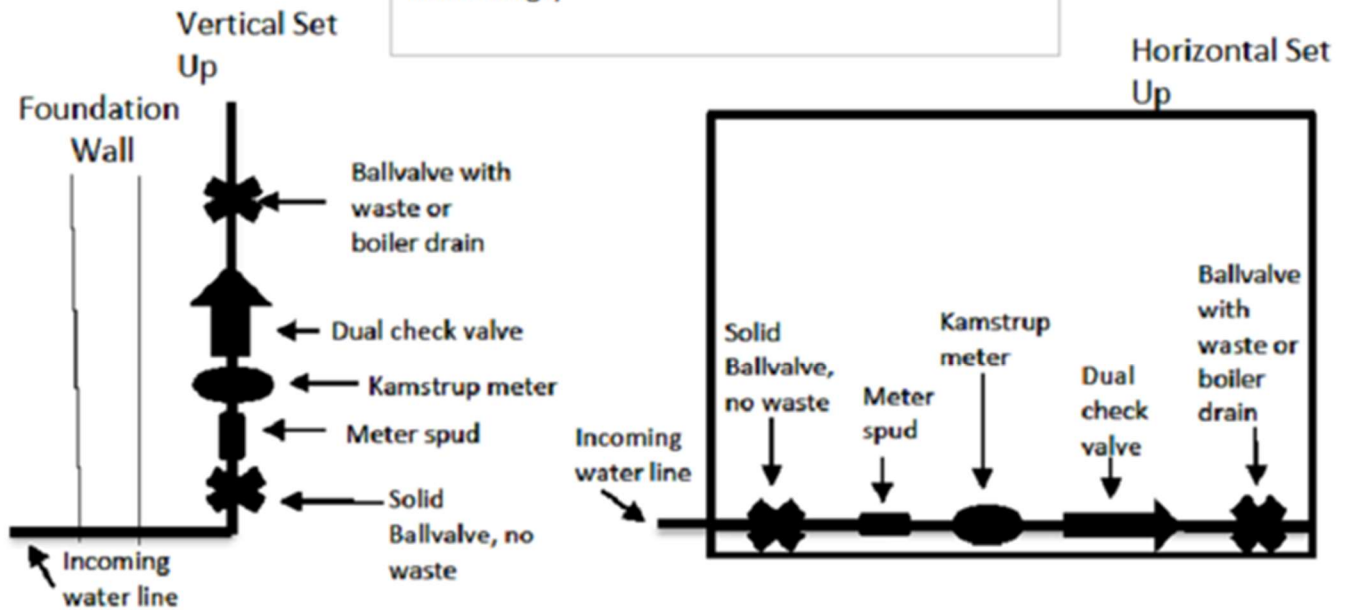

## New Meter Installation – Commercial

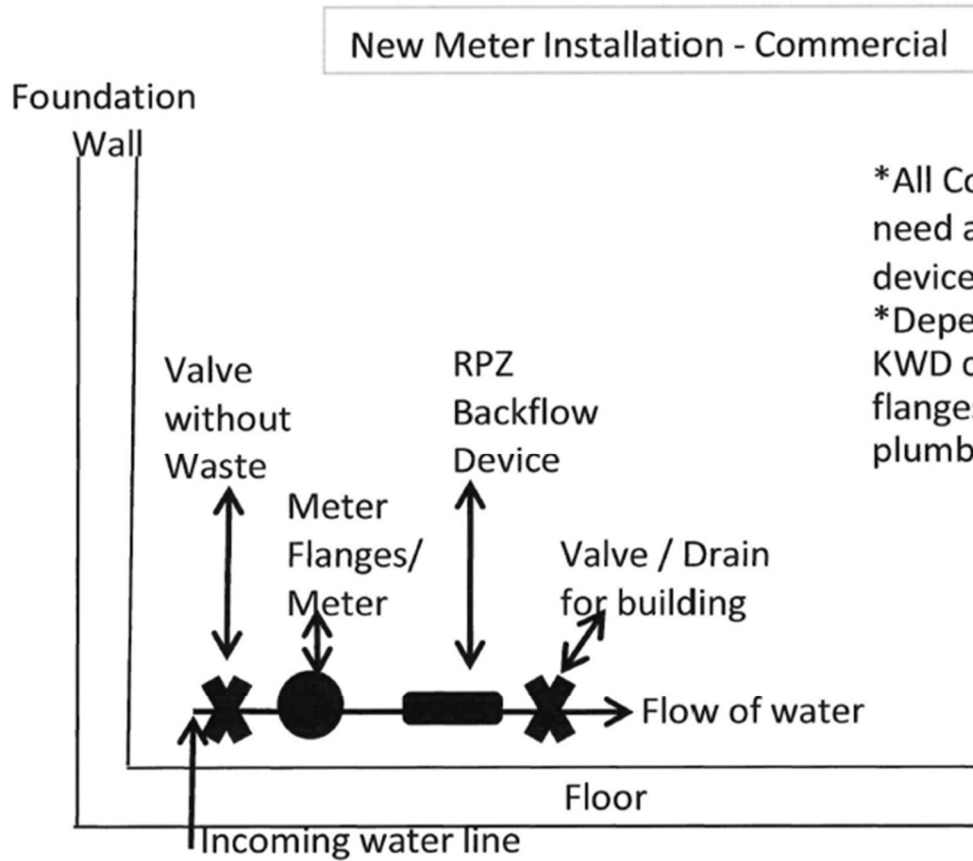

\*All Commercial properties need a testable RPZ backflow device.

\*Depending on size of meter, KWD can provide different flanges or tail pieces for the plumber.

## New Meter Installation – Eliot Deduct

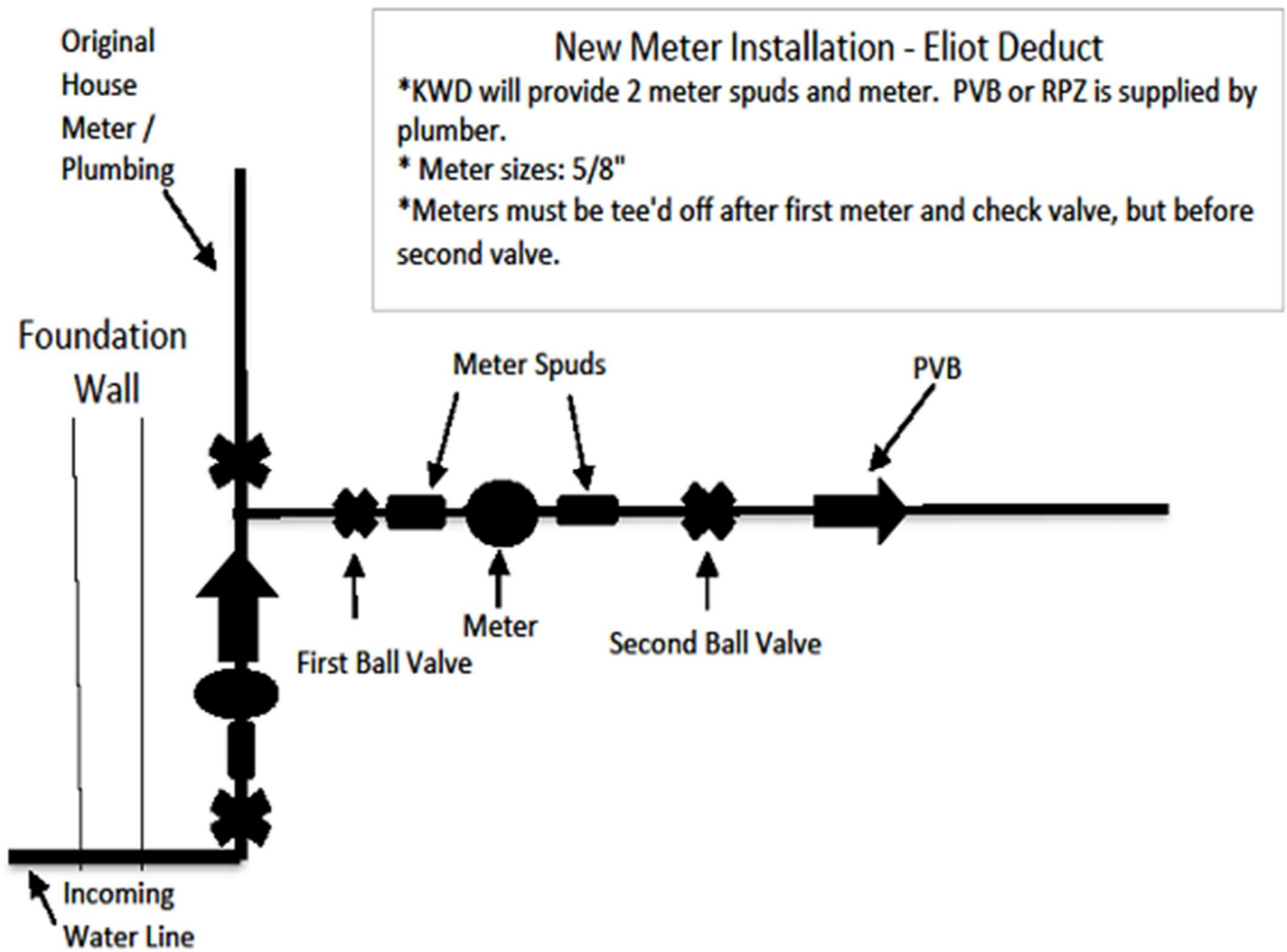

# New Meter Installation - Kittery Second Irrigation

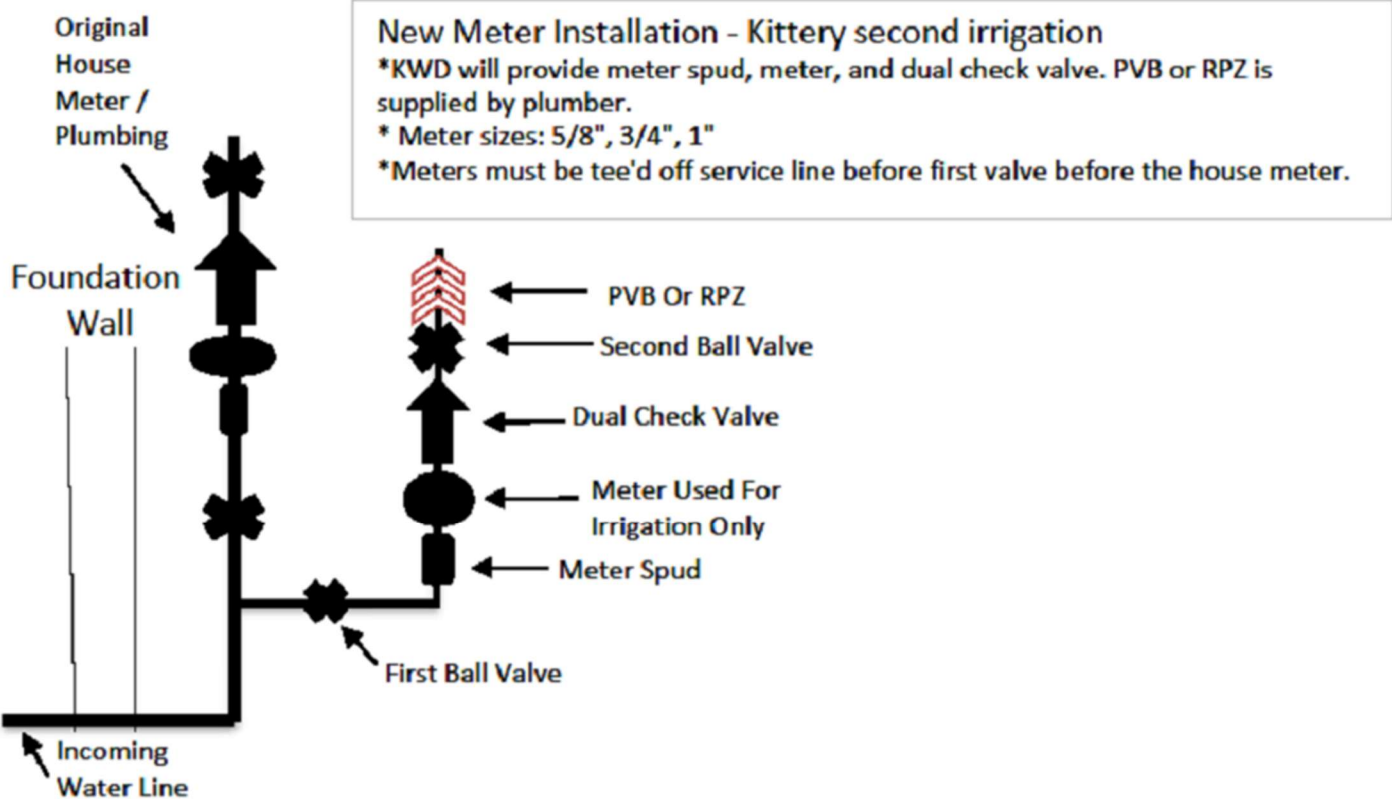

# KITTERY WATER DISTRICT

## WATER LINE CONSTRUCTION SPECIFICATIONS

APRIL 2026

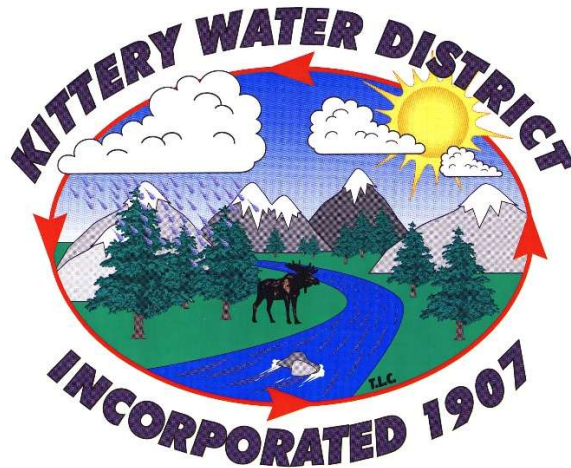

If you have any questions, please call the office at (207) 439-1128 or email at [info@kitterywater.org](mailto:info@kitterywater.org). Your inquiry will be directed to the appropriate staff member, who will follow up as quickly as is possible.

# Table of Contents

Introduction .....	3
Before Beginning Any Work .....	4
Installation Requirements.....	5
Water Line Construction Material Specifications.....	8
Standard 2 - Inch Blow Off Detail .....	11
New Meter Installation – Residential.....	12
New Meter Installation – Commercial.....	13
New Meter Installation – Eliot Deduct .....	14
New Meter Installation- Kittery Second Irrigation.....	15

## **Introduction**

This information is intended to inform and guide homeowners and contractors regarding procedures to follow while working on Kittery Water District (here after KWD) water lines. **This summary does not relieve the owner/contractor of the responsibility for meeting all State and Federal requirements pertaining to the installation of water and sewer lines.**

NOTE: Provided that both the material specifications and installation requirements of the KWD are followed, upon successful installation and testing of the underground and aboveground infrastructure, KWD will accept the ownership of the infrastructure for perpetuity. If the infrastructure is NOT located within the Town or State right-of-way, a Utility Easement will need to be issued to the KWD.

***NOTE: ALL PARTIES ARE STRONGLY ENCOURAGED TO READ THIS BOOKLET AND CALL WITH ANY QUESTIONS PRIOR TO STARTING WORK.***

*This information is subject to revision.*

## **Before Beginning Any Work**

1. The KWD requires **at least one week's notice** before any work can begin. This allows the KWD time to review the project with the owner/contractor and schedule installations and inspections, etc. **The owner/contractor must contact the KWD at (207) 439-1128 prior to beginning work.**
2. Pursuant to Federal Law, the owner/contractor must contact Dig Safe at 811, or 1-888-344-7233 at least three (3) working days prior to the date work is scheduled to begin. A Dig Safe Project Number is required prior to excavation.
3. The owner/contractor shall not operate any hydrants, valves or curb stops that are the property of the KWD, without the expressed permission of the KWD.
4. The owner/contractor shall be responsible for notifying all users/property owners affected, prior to shutting off any services. Appropriate agencies shall also be notified.

# **Installation Requirements**

## **INSPECTION SERVICES:**

Installation inspections will be performed by the District or its representative and paid for by the Developer or Contractor. Full time inspections will be performed by the District or its representative at the jobbing hourly rate. Inspections will be performed during regular business hours 7:00 am – 3:00 pm, Monday – Friday, unless a prior request is issued and approved by the KWD.

## **BEDDING AND BACKFILL:**

- Ledge must be fully excavated a minimum of 12” below and 12” on either side of the pipe.
- A Minimum of 6” of clean sand bedding under the pipe and 12” on either side of the pipe is required.
- Pipe Bedding – AWWA C600 Pipe Laying Sec. 4 standards shall be followed for the installations of water mains and appurtenances. Trenches shall be flat bottomed, with 6” of compacted clean sand beneath and 12” above the pipe. Where ledge is encountered, 12” of compacted clean sand shall be installed beneath the pipe. The trench will be kept dewatered during pipe laying.  
The pipe bedding shall be clean granular sand, free from organic matter, frozen material or any other objectionable material and shall meet the following requirement: 100% passing a 2” sieve.
- Stone Dust is NOT an acceptable substitute for sand.
- A Minimum of 12” of compacted sand above the pipe is required. Compaction can be accomplished by either the excavator bucket or a mechanical compactor.
- The remainder of the trench is to have compacted backfill material pre-approved by the District or its representative. Compaction of this material must be by a mechanical compactor.
- Minimum earth cover over the top of the pipe is 5’-0” (top of pipe to finish grade).
- Locking Tyton / Fastite gaskets shall be installed in the last 3 sections of pipe that is assembled before installing the blow-off assembly.
- The Blow-Off assembly will require that an MJ Tap Cap be installed which will require a spigot end of the pipe. (additional details below).
- Field cutting of pipe is not allowed within 3 feet of the bell of the pipe, unless the nominal O.D. of the pipe is maintained.

## **BLOW-OFF INSTALLATION (SEE DETAIL SHEETS):**

- High density polyethylene (H.D.P.E.) blow-offs are fabricated by KWD (time and material rates apply), and installed by the contractor.
- Valve shall be 2” ball valve, Riser shall be 2” H.D.P.E. plastic pipe.
- Contractor is responsible for backfilling once the Blow-Off and thrust blocks are installed.
- Sand backfill is required from the base of the valve and riser pipe to the top of the ground.
- Care must be taken not to dig beyond the blow-off installation area, such that thrust blocks can be set against undisturbed soil.
- 26” top flange valve box top sections and covers are to be installed over all Blow-Off assemblies, over the service box and over the riser pipe.

### **SERVICES LINE INSTALLATIONS:**

- Upon completion of the water main, and a passing pressure test, installation of services may be proceed.
- On Ductile mains, 1” direct taps will be performed, to a 1” cc Corp, to 1” “K” Copper Service Line, to a 1” Ballvalve Curb stop. The Curb stop will have a 36” s.s. Service Rod and a 4.5’-5.5’ Service Box. A Bibby with Cover labeled “Water” will be installed over the Service Box.
- On HDPE mains, 1” Service Saddles will be installed prior to tapping the main. A 1” cc Corp, to 1” CTS plastic Service Line, to a 1” Ballvalve Curb stop. The Curb stop will have a 36” s.s. Service Rod and a 4.5’-5.5’ Service Box. Tracer wire will be installed to the CTS line. A 6” top flange valve box top section with Cover labeled “WATER” will be installed over the Service Box.
- Clean sand bedding is also required 6” below the copper tubing and 12” to the sides and above. Sand backfill is also required around the service box, from the foot piece to the cap.
- Services that reach or exceed 150 feet from the curb stop will require a meter vault to be installed.

### **TEST SERVICE / CHLORINATION TAP:**

The KWD or Contractor shall install a 1” corporation and a CTS plastic riser with a 1” curb stop cnpj x feip, on the first length of water main that is installed, as close to the mainline valve as is practical. Upon successful completion of a pressure test, chlorination and a negative bacteria test, the Contractor shall excavate to allow removal of the test service and installation of a brass plug by either KWD or the Contractor (time and material rates apply).

### **FIRE HYDRANT INSTALLATIONS:**

- The traffic break flange of the hydrant shall not be less than 2” above the finish grade, nor more than 6” above the finish grade.
- Sand backfill is required around the barrel of the hydrant, from the shoe to the ground’s surface.
- Valve anchoring tees are to be used for all hydrant installations and lateral water mains.
- Marker poles will be provided by the District and installed by the contractor in the appropriate location (material rates apply).

### **WATER MAIN ACCEPTANCE POLICY:**

- The newly installed water main will be filled, flushed, hydrostatically tested and chlorinated by the contractor.
- A negative bacteria result is needed before the water is used for any reason. The contractor or KWD will take this sample and have it analyzed.
- An as-built drawing of the water main installation performed by a licensed surveyor or engineer is required before acceptance of the main by KWD.
- Receipt of an electronic version of the project plan.
- Acknowledgement and execution of any agreements (fire protection lines, fire hydrants, etc.).
- Execution of an Easement to the KWD, for any mains installed in non-public right of ways. This includes both the drafting and recording of the Easement.
- Payment shall be made to KWD for all invoiced services and materials.

## **METERS:**

- Meters are both supplied and installed by KWD (time and material rates apply).
- A sketch is available from the District, outlining the required plumbing setup to receive the meter.
- Type “L” Copper should be used in the installation.

## **NOTES:**

- All materials that are installed are to be made in the USA or Canada, unless otherwise approved by the KWD.
- Material Submittal Sheets (Cut Sheets) shall be submitted to the KWD for approvable prior purchasing the materials.
- Inspection and service work performed by KWD will be billed at the District’s current time and material rates. Services provided by a third party will be billed at their rate.
- The horizontal distance between water and sewer lines shall be a minimum of 10 feet. Anytime a sewer line crosses above a water main, one full section of typical sewer pipe must be replaced with a full section of SDR-21 quality pipe. The full section of SDR-21 pipe shall be centered upon the crossing to maximize joint distance from the watermain and shall have a minimum clearance of 18” above the watermain.
- During new construction groundwork, the Owner / Contractor is responsible for protecting any service or meter that may be in danger of freezing. Associated damage repair costs will be the responsibility of the Owner / Contractor.
- The installation of H.D.P.E. main and CTS Plastic service lines will require the installation of Copper Head Brand tracing wire and Snake Bite Brand connectors. The KWD has very specific requirements for the installation of the tracer wire. The on-site inspector will provide detailed guidance at the time of installation.
- GPK Products, Inc. Schedule 40 x SDR-35 G “No Stop” adaptors must be used for all SDR-35 to SDR-21 connections. Connections of SDR-21 to other types of sewer pipe shall use solid couplings. Flexible couplings will NOT be permitted.

# **Water Line Construction Material Specifications**

## **WATER MAIN:**

- Ductile Iron
- Class 52 thickness
- Tyton / Fastite joint
- Double cement lined
- Zinc coated

## **ALTERNATE WATER MAIN MATERIAL:**

- High Density Polyethylene (H.D.P.E.)
- SDR 11
- Butt Fusion / Electrofusion Couplings
- Blue Stripe
- Copper Head Brand tracer wire is required on the main and all laterals

## **DUCTILE IRON FITTINGS:**

- Class 350
- Made in the USA or Canada

## **DUCTILE IRON GATE VALVES:**

- 250 P.S.I. working pressure
- Open left
- Resilient wedge
- Valves 16" or greater must be Horizontal with Bevel Gear
- Stainless steel nuts and bolts
- Stainless steel or bronze operating nut
- Valve centering rings are required
- Mud plugs are required

## **FIRE HYDRANTS:**

- AFC Waterous Pacer WB 67
- Clow Medallion
- Kennedy Valve Guardian K81-D
- Open left
- Non draining barrel

## **SERVICE BOXES:**

- 4 ½' - 5 ½' height, cap with rope thread and pentagon nut

**VALVE BOXES:**

- Cast iron
- 36” top flange
- 36” bottom base belled (minimum length)
- 5 ¼” diameter
- Drop in cover with pick hole with the word “WATER” cast in the cover
- Made in the USA or Canada

**CORPORATIONS:**

- Minimum size 1” for residential
- Mac Pac compression style nut
- Ball construction
- AY McDonald or Ford brand
- CC thread type

**CURB STOPS:**

- Minimum size 1” for residential
- Mac Pac compression style nut
- Ball construction
- AY McDonald or Ford brand

**SERVICE LINES:**

- Service lines shall be K-copper tubing
- Minimum size of tubing is 1”
- CTS Plastic tubing may be used only when installing an H.D.P.E. main
- ALL service boxes are to be protected using a 5 ¼” x 6” valve box top extension with the cover stamped “WATER”

**STAINLESS STEEL SERVICE RODS:**

- 5/8” x 36” long, with Brass Cotter Pins

**TAPPING SLEEVE:**

- Series 304 stainless steel
- Ductile iron or stainless steel welded flange
- Size on size taps are NOT permitted on cast iron water mains

**RETAINER GLANDS:**

- Romac grip ring brand (R-Blue T-Bolts and nuts required)
- MJ Field Lok brand (R-Blue T-Bolts and nuts required)
- MEGA Lug brand (R-Blue T-Bolts and nuts required)

**SERVICE SADDLES:**

- Ductile Iron body
- Nylon coated body
- Double stainless steel straps
- Electrofusion service saddles with cc threads are required when using H.D.P.E. pipe



**2" Female Poly Cam Fitting with Plug, Valve Box Top Section and Cover.**

**KWD to provide 2" SDR Riser Pipe, and the Contractor will provide all other fittings per KWD detail**

**2" SDR 11 HDPE Riser (provided by the KWD)**

**2" Male Poly Cam Fitting, 2" Elbow, 2" x 12" Nipple, 2" FE x FE ball valve curb stop, 2" x 6" Nipple, 36" stainless steel rod, service box, Valve Box Top Section and Cover.**

# **KITTERY WATER DISTRICT**

## **Standard 2 - Inch Blow Off Detail**

### **This is a parts list beginning at the tapped MJ Cap or Plug:**

- 2" x 6" Brass Nipple
- 2" FE x FE Ball Valve Curb Stop
- 2" x 12" Brass Nipple
- 2" Brass Elbow
- 2" Male Poly Cam \*
- 2" SDR11 H.D.P.E. Pipe \*
- 2" Female Poly Cam \*
- 2" Brass Plug

### **Also: After the assembly is installed:**

- Service Box Foot Piece
- Service Box (4' - 6" x 5' - 6")
- 36" x 5/8" Diameter Stainless Steel Service Rod
- Valve Box Cover (2)
- 26" Valve Box Top Section (2)

\* Riser Pipe is welded to the specified length by the Kittery Water District

## New Meter Installation – Residential

### New Meter Installation - Residential

\*KWD will provide meter spud, meter, and dual check valve.  
Meter sizes: 5/8", 3/4", 1" (Determined by water usage)

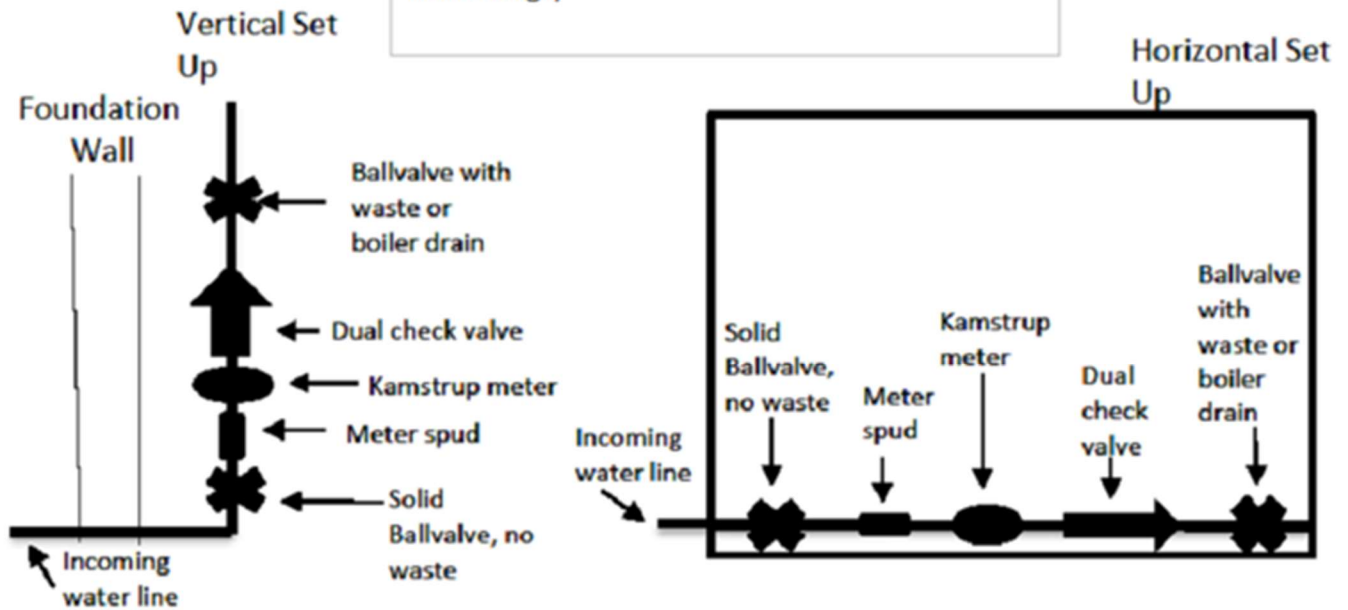

## New Meter Installation – Commercial

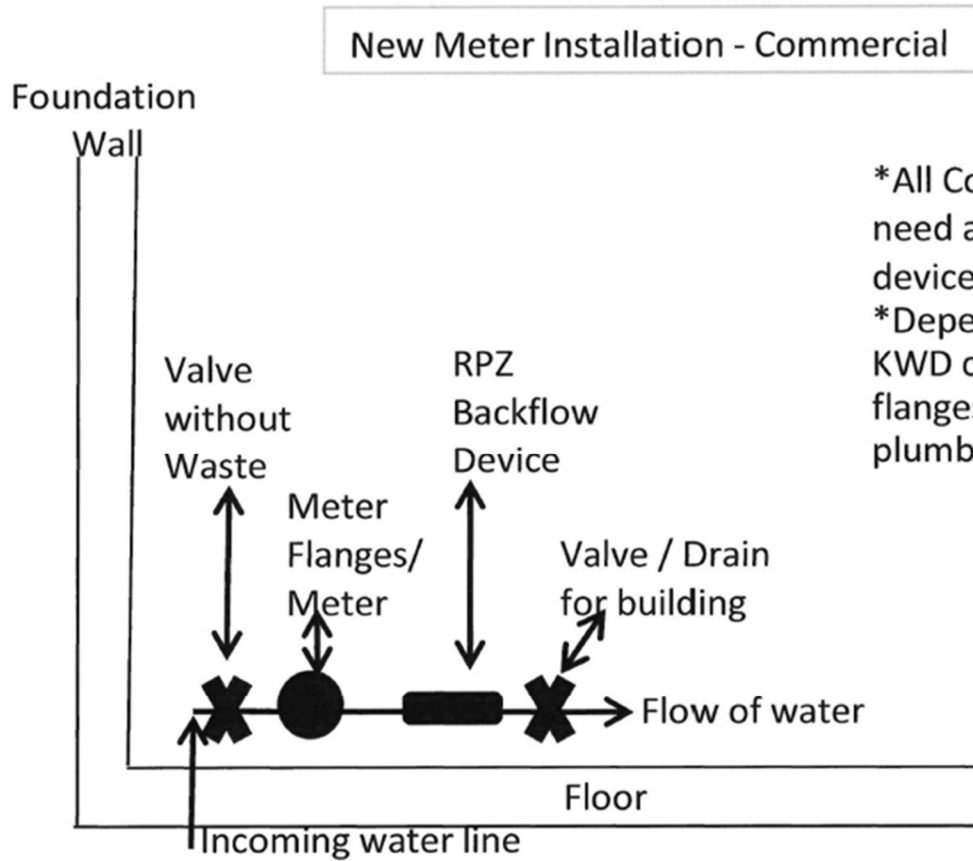

\*All Commercial properties need a testable RPZ backflow device.

\*Depending on size of meter, KWD can provide different flanges or tail pieces for the plumber.

## New Meter Installation – Eliot Deduct

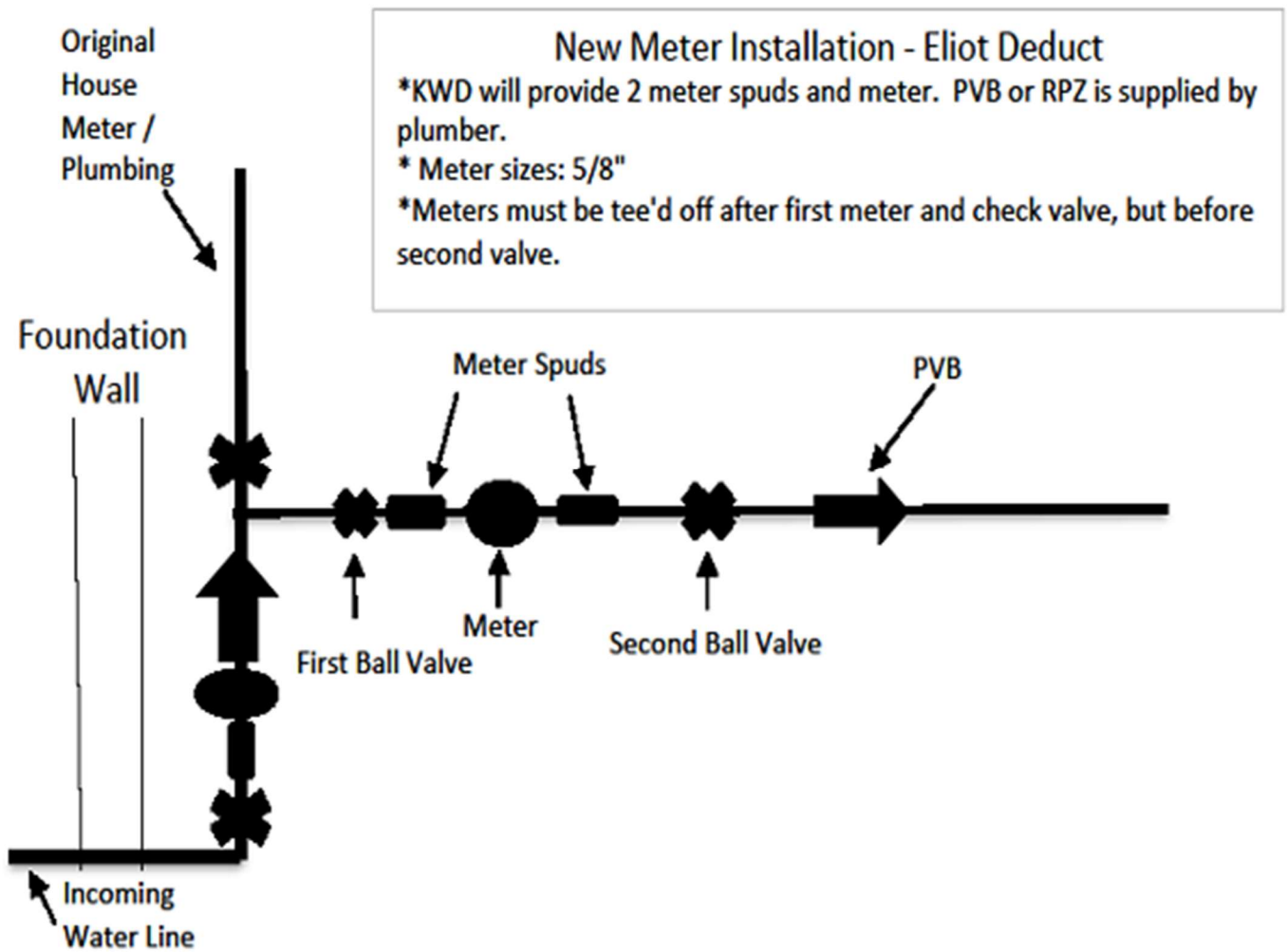

# New Meter Installation - Kittery Second Irrigation

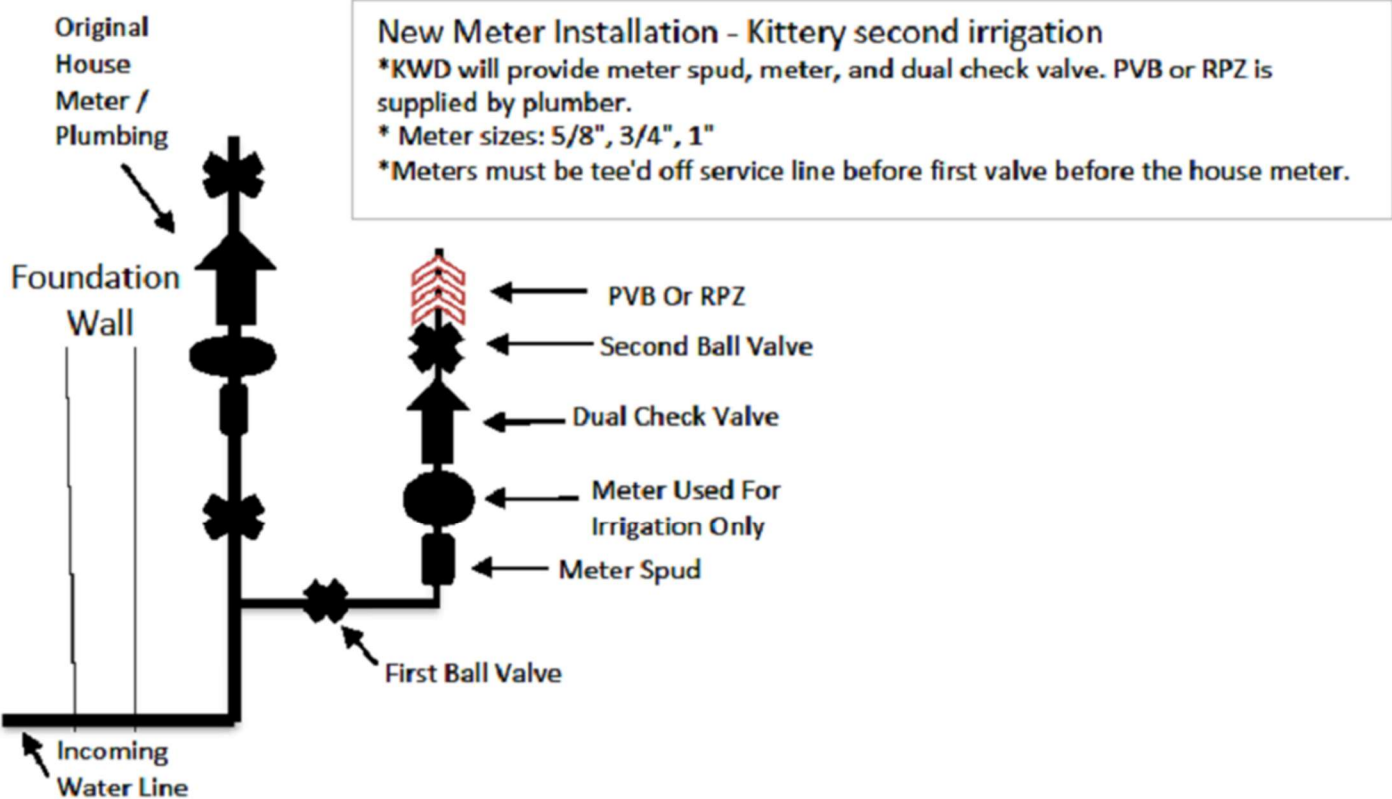

# KITTERY WATER DISTRICT

## WATER LINE CONSTRUCTION SPECIFICATIONS

APRIL 2026



If you have any questions, please call the office at (207) 439-1128 or email at [info@kitterywater.org](mailto:info@kitterywater.org). Your inquiry will be directed to the appropriate staff member, who will follow up as quickly as is possible.

# Table of Contents

Introduction .....	3
Before Beginning Any Work .....	4
Installation Requirements.....	5
Water Line Construction Material Specifications.....	8
Standard 2 - Inch Blow Off Detail .....	11
New Meter Installation – Residential.....	12
New Meter Installation – Commercial.....	13
New Meter Installation – Eliot Deduct .....	14
New Meter Installation- Kittery Second Irrigation.....	15

## **Introduction**

This information is intended to inform and guide homeowners and contractors regarding procedures to follow while working on Kittery Water District (here after KWD) water lines. **This summary does not relieve the owner/contractor of the responsibility for meeting all State and Federal requirements pertaining to the installation of water and sewer lines.**

NOTE: Provided that both the material specifications and installation requirements of the KWD are followed, upon successful installation and testing of the underground and aboveground infrastructure, KWD will accept the ownership of the infrastructure for perpetuity. If the infrastructure is NOT located within the Town or State right-of-way, a Utility Easement will need to be issued to the KWD.

***NOTE: ALL PARTIES ARE STRONGLY ENCOURAGED TO READ THIS BOOKLET AND CALL WITH ANY QUESTIONS PRIOR TO STARTING WORK.***

*This information is subject to revision.*

## **Before Beginning Any Work**

1. The KWD requires **at least one week's notice** before any work can begin. This allows the KWD time to review the project with the owner/contractor and schedule installations and inspections, etc. **The owner/contractor must contact the KWD at (207) 439-1128 prior to beginning work.**
2. Pursuant to Federal Law, the owner/contractor must contact Dig Safe at 811, or 1-888-344-7233 at least three (3) working days prior to the date work is scheduled to begin. A Dig Safe Project Number is required prior to excavation.
3. The owner/contractor shall not operate any hydrants, valves or curb stops that are the property of the KWD, without the expressed permission of the KWD.
4. The owner/contractor shall be responsible for notifying all users/property owners affected, prior to shutting off any services. Appropriate agencies shall also be notified.

## **Installation Requirements**

### **INSPECTION SERVICES:**

Installation inspections will be performed by the District or its representative and paid for by the Developer or Contractor. Full time inspections will be performed by the District or its representative at the jobbing hourly rate. Inspections will be performed during regular business hours 7:00 am – 3:00 pm, Monday – Friday, unless a prior request is issued and approved by the KWD.

### **BEDDING AND BACKFILL:**

- Ledge must be fully excavated a minimum of 12” below and 12” on either side of the pipe.
- A Minimum of 6” of clean sand bedding under the pipe and 12” on either side of the pipe is required.
- Pipe Bedding – AWWA C600 Pipe Laying Sec. 4 standards shall be followed for the installations of water mains and appurtenances. Trenches shall be flat bottomed, with 6” of compacted clean sand beneath and 12” above the pipe. Where ledge is encountered, 12” of compacted clean sand shall be installed beneath the pipe. The trench will be kept dewatered during pipe laying.  
The pipe bedding shall be clean granular sand, free from organic matter, frozen material or any other objectionable material and shall meet the following requirement: 100% passing a 2” sieve.
- Stone Dust is NOT an acceptable substitute for sand.
- A Minimum of 12” of compacted sand above the pipe is required. Compaction can be accomplished by either the excavator bucket or a mechanical compactor.
- The remainder of the trench is to have compacted backfill material pre-approved by the District or its representative. Compaction of this material must be by a mechanical compactor.
- Minimum earth cover over the top of the pipe is 5’-0” (top of pipe to finish grade).
- Locking Tyton / Fastite gaskets shall be installed in the last 3 sections of pipe that is assembled before installing the blow-off assembly.
- The Blow-Off assembly will require that an MJ Tap Cap be installed which will require a spigot end of the pipe. (additional details below).
- Field cutting of pipe is not allowed within 3 feet of the bell of the pipe, unless the nominal O.D. of the pipe is maintained.

### **BLOW-OFF INSTALLATION (SEE DETAIL SHEETS):**

- High density polyethylene (H.D.P.E.) blow-offs are fabricated by KWD (time and material rates apply), and installed by the contractor.
- Valve shall be 2” ball valve, Riser shall be 2” H.D.P.E. plastic pipe.
- Contractor is responsible for backfilling once the Blow-Off and thrust blocks are installed.
- Sand backfill is required from the base of the valve and riser pipe to the top of the ground.
- Care must be taken not to dig beyond the blow-off installation area, such that thrust blocks can be set against undisturbed soil.
- 26” top flange valve box top sections and covers are to be installed over all Blow-Off assemblies, over the service box and over the riser pipe.

### **SERVICES LINE INSTALLATIONS:**

- Upon completion of the water main, and a passing pressure test, installation of services may be proceed.
- On Ductile mains, 1” direct taps will be performed, to a 1” cc Corp, to 1” “K” Copper Service Line, to a 1” Ballvalve Curb stop. The Curb stop will have a 36” s.s. Service Rod and a 4.5’-5.5’ Service Box. A Bibby with Cover labeled “Water” will be installed over the Service Box.
- On HDPE mains, 1” Service Saddles will be installed prior to tapping the main. A 1” cc Corp, to 1” CTS plastic Service Line, to a 1” Ballvalve Curb stop. The Curb stop will have a 36” s.s. Service Rod and a 4.5’-5.5’ Service Box. Tracer wire will be installed to the CTS line. A 6” top flange valve box top section with Cover labeled “WATER” will be installed over the Service Box.
- Clean sand bedding is also required 6” below the copper tubing and 12” to the sides and above. Sand backfill is also required around the service box, from the foot piece to the cap.
- Services that reach or exceed 150 feet from the curb stop will require a meter vault to be installed.

### **TEST SERVICE / CHLORINATION TAP:**

The KWD or Contractor shall install a 1” corporation and a CTS plastic riser with a 1” curb stop cnpj x feip, on the first length of water main that is installed, as close to the mainline valve as is practical. Upon successful completion of a pressure test, chlorination and a negative bacteria test, the Contractor shall excavate to allow removal of the test service and installation of a brass plug by either KWD or the Contractor (time and material rates apply).

### **FIRE HYDRANT INSTALLATIONS:**

- The traffic break flange of the hydrant shall not be less than 2” above the finish grade, nor more than 6” above the finish grade.
- Sand backfill is required around the barrel of the hydrant, from the shoe to the ground’s surface.
- Valve anchoring tees are to be used for all hydrant installations and lateral water mains.
- Marker poles will be provided by the District and installed by the contractor in the appropriate location (material rates apply).

### **WATER MAIN ACCEPTANCE POLICY:**

- The newly installed water main will be filled, flushed, hydrostatically tested and chlorinated by the contractor.
- A negative bacteria result is needed before the water is used for any reason. The contractor or KWD will take this sample and have it analyzed.
- An as-built drawing of the water main installation performed by a licensed surveyor or engineer is required before acceptance of the main by KWD.
- Receipt of an electronic version of the project plan.
- Acknowledgement and execution of any agreements (fire protection lines, fire hydrants, etc.).
- Execution of an Easement to the KWD, for any mains installed in non-public right of ways. This includes both the drafting and recording of the Easement.
- Payment shall be made to KWD for all invoiced services and materials.

## **METERS:**

- Meters are both supplied and installed by KWD (time and material rates apply).
- A sketch is available from the District, outlining the required plumbing setup to receive the meter.
- Type “L” Copper should be used in the installation.

## **NOTES:**

- All materials that are installed are to be made in the USA or Canada, unless otherwise approved by the KWD.
- Material Submittal Sheets (Cut Sheets) shall be submitted to the KWD for approvable prior purchasing the materials.
- Inspection and service work performed by KWD will be billed at the District’s current time and material rates. Services provided by a third party will be billed at their rate.
- The horizontal distance between water and sewer lines shall be a minimum of 10 feet. Anytime a sewer line crosses above a water main, one full section of typical sewer pipe must be replaced with a full section of SDR-21 quality pipe. The full section of SDR-21 pipe shall be centered upon the crossing to maximize joint distance from the watermain and shall have a minimum clearance of 18” above the watermain.
- During new construction groundwork, the Owner / Contractor is responsible for protecting any service or meter that may be in danger of freezing. Associated damage repair costs will be the responsibility of the Owner / Contractor.
- The installation of H.D.P.E. main and CTS Plastic service lines will require the installation of Copper Head Brand tracing wire and Snake Bite Brand connectors. The KWD has very specific requirements for the installation of the tracer wire. The on-site inspector will provide detailed guidance at the time of installation.
- GPK Products, Inc. Schedule 40 x SDR-35 G “No Stop” adaptors must be used for all SDR-35 to SDR-21 connections. Connections of SDR-21 to other types of sewer pipe shall use solid couplings. Flexible couplings will NOT be permitted.

# **Water Line Construction Material Specifications**

## **WATER MAIN:**

- Ductile Iron
- Class 52 thickness
- Tyton / Fastite joint
- Double cement lined
- Zinc coated

## **ALTERNATE WATER MAIN MATERIAL:**

- High Density Polyethylene (H.D.P.E.)
- SDR 11
- Butt Fusion / Electrofusion Couplings
- Blue Stripe
- Copper Head Brand tracer wire is required on the main and all laterals

## **DUCTILE IRON FITTINGS:**

- Class 350
- Made in the USA or Canada

## **DUCTILE IRON GATE VALVES:**

- 250 P.S.I. working pressure
- Open left
- Resilient wedge
- Valves 16" or greater must be Horizontal with Bevel Gear
- Stainless steel nuts and bolts
- Stainless steel or bronze operating nut
- Valve centering rings are required
- Mud plugs are required

## **FIRE HYDRANTS:**

- AFC Waterous Pacer WB 67
- Clow Medallion
- Kennedy Valve Guardian K81-D
- Open left
- Non draining barrel

## **SERVICE BOXES:**

- 4 ½' - 5 ½' height, cap with rope thread and pentagon nut

**VALVE BOXES:**

- Cast iron
- 36” top flange
- 36” bottom base belled (minimum length)
- 5 ¼” diameter
- Drop in cover with pick hole with the word “WATER” cast in the cover
- Made in the USA or Canada

**CORPORATIONS:**

- Minimum size 1” for residential
- Mac Pac compression style nut
- Ball construction
- AY McDonald or Ford brand
- CC thread type

**CURB STOPS:**

- Minimum size 1” for residential
- Mac Pac compression style nut
- Ball construction
- AY McDonald or Ford brand

**SERVICE LINES:**

- Service lines shall be K-copper tubing
- Minimum size of tubing is 1”
- CTS Plastic tubing may be used only when installing an H.D.P.E. main
- ALL service boxes are to be protected using a 5 ¼” x 6” valve box top extension with the cover stamped “WATER”

**STAINLESS STEEL SERVICE RODS:**

- 5/8” x 36” long, with Brass Cotter Pins

**TAPPING SLEEVE:**

- Series 304 stainless steel
- Ductile iron or stainless steel welded flange
- Size on size taps are NOT permitted on cast iron water mains

**RETAINER GLANDS:**

- Romac grip ring brand (R-Blue T-Bolts and nuts required)
- MJ Field Lok brand (R-Blue T-Bolts and nuts required)
- MEGA Lug brand (R-Blue T-Bolts and nuts required)

**SERVICE SADDLES:**

- Ductile Iron body
- Nylon coated body
- Double stainless steel straps
- Electrofusion service saddles with cc threads are required when using H.D.P.E. pipe



**2" Female Poly Cam Fitting with Plug, Valve Box Top Section and Cover.**

**KWD to provide 2" SDR Riser Pipe, and the Contractor will provide all other fittings per KWD detail**

**2" SDR 11 HDPE Riser (provided by the KWD)**

**2" Male Poly Cam Fitting, 2" Elbow, 2" x 12" Nipple, 2" FE x FE ball valve curb stop, 2" x 6" Nipple, 36" stainless steel rod, service box, Valve Box Top Section and Cover.**

# **KITTERY WATER DISTRICT**

## **Standard 2 - Inch Blow Off Detail**

### **This is a parts list beginning at the tapped MJ Cap or Plug:**

- 2" x 6" Brass Nipple
- 2" FE x FE Ball Valve Curb Stop
- 2" x 12" Brass Nipple
- 2" Brass Elbow
- 2" Male Poly Cam \*
- 2" SDR11 H.D.P.E. Pipe \*
- 2" Female Poly Cam \*
- 2" Brass Plug

### **Also: After the assembly is installed:**

- Service Box Foot Piece
- Service Box (4' - 6" x 5' - 6")
- 36" x 5/8" Diameter Stainless Steel Service Rod
- Valve Box Cover (2)
- 26" Valve Box Top Section (2)

\* Riser Pipe is welded to the specified length by the Kittery Water District

## New Meter Installation – Residential

### New Meter Installation - Residential

\*KWD will provide meter spud, meter, and dual check valve.  
Meter sizes: 5/8", 3/4", 1" (Determined by water usage)

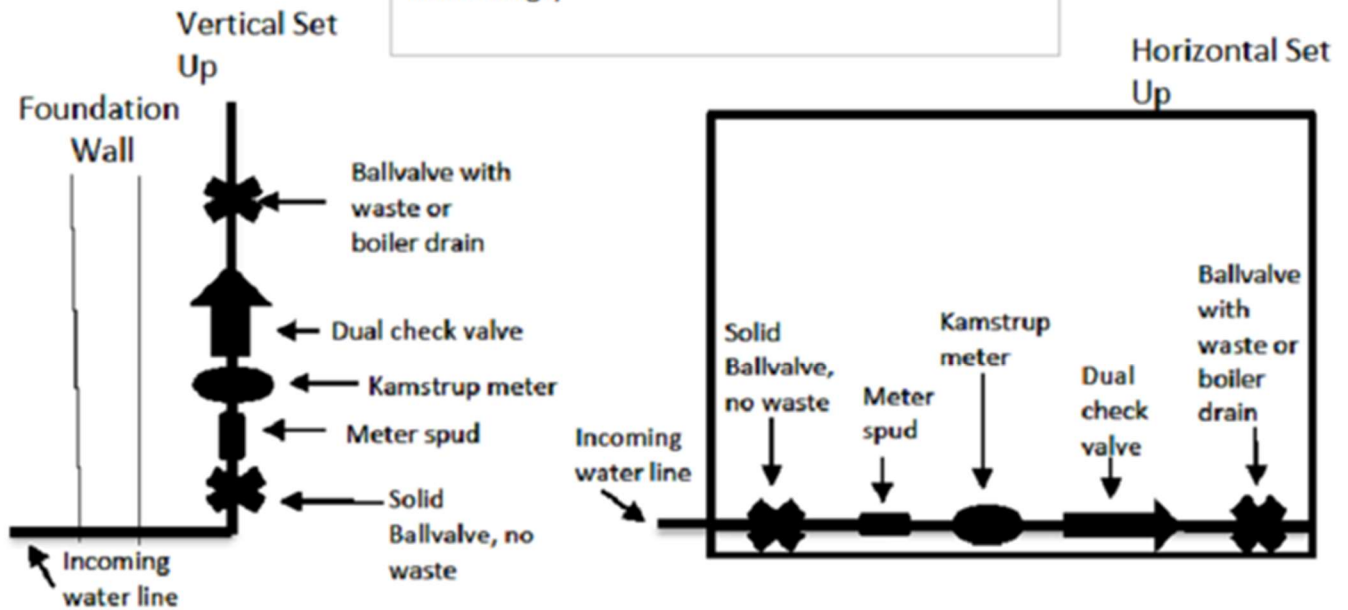

## New Meter Installation – Commercial

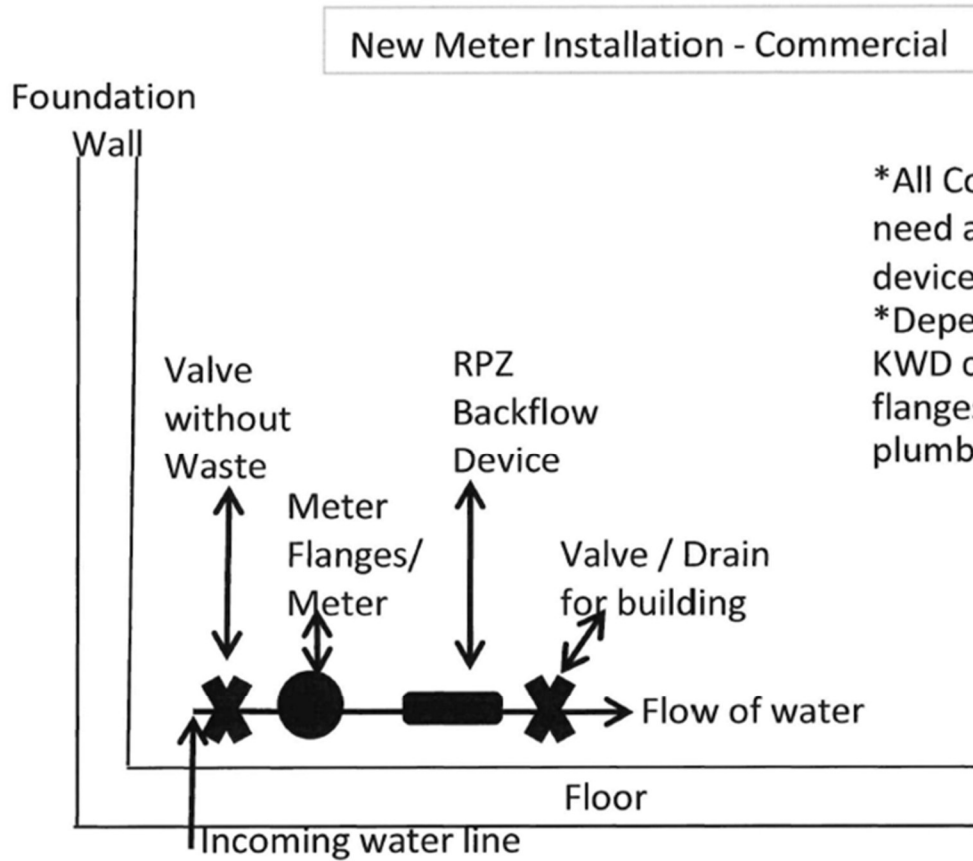

\*All Commercial properties need a testable RPZ backflow device.

\*Depending on size of meter, KWD can provide different flanges or tail pieces for the plumber.

## New Meter Installation – Eliot Deduct

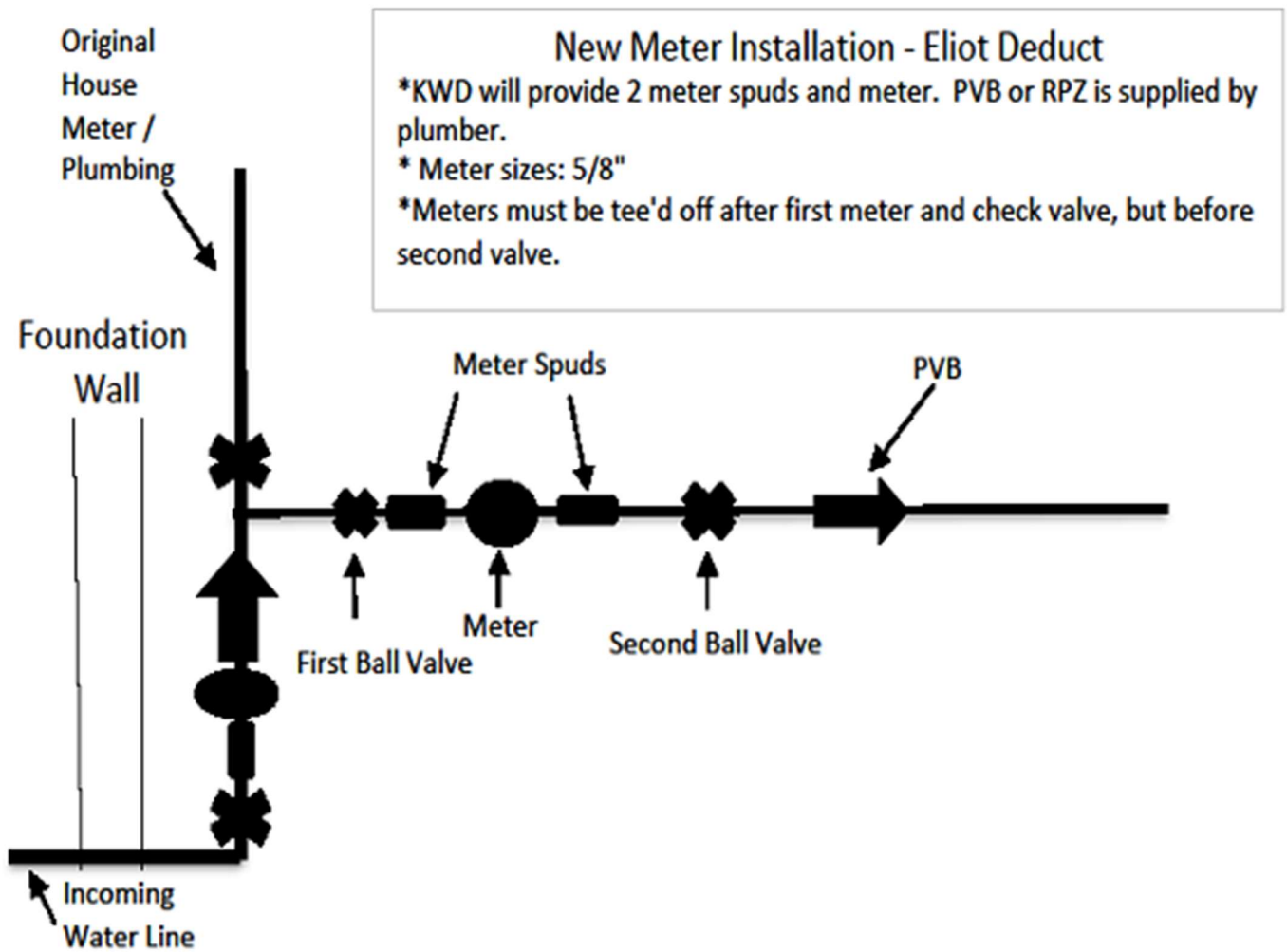

# New Meter Installation - Kittery Second Irrigation

